

Mathematical Characteristics of ROXY Index (II): Periods of Intra-metropolitan Spatial-cycle Paths and Theoretically-ideal Formulations of ROXY Index

Noriyuki Hiraoka*

Tatsuhiko Kawashima*

Contents

Introduction

Part I Periods of Intra-metropolitan Spatial Cycles

- 1 Values of ROXY Index Based on Annual Data: For Five Railway-line Regions in Tokyo Metropolitan Area
- 2 Eigenvalue Analysis for Periods of Spatial-cycle Paths: Application of Econometric Approach to Values of ROXY Index Obtained for the Stage of Decentralization

Part II Theoretically-ideal Formulations of ROXY Index

- 3 Conventional Formulation of ROXY Index: Definition and Drawbacks for Discrete-linear Region
- 4 Theoretically-ideal Formulations of ROXY Index: Definition, Normalization, and Interpretations for One-dimensional Continuous-linear Region and Two-dimensional Fan-shaped Region
- 5 Suggested Formulations of ROXY Index: Approximation Means for Continuous-linear Region and Fan-shaped Region
- 6 Comparative Analysis on Values of ROXY Indices for Three Types of Formulations: Discrete-linear Region, Continuous-linear Region, and Fan-shaped Region
- 7 Lessons and Suggestions from Investigations in Part II

Conclusion: Research Agenda

Notes

References

Appendix

Abstract

There are few systematical quantitative tools to study spatial-cycle paths of large metropolitan areas, partly because there exist difficulties in quantitatively grasp basic characteristics embodied in the phenomena of spatial cycles. The ROXY index methods, however, can apply not only to the investigation of identifying stages of spatial-cycle processes, but also to the examination of the periods of the spatial-cycle path with the aid of eigenvalues used in the field of econometrics. An examination of a set of annual data for five railway-line regions in Tokyo metropolitan area, supports the above expectation. This paper concludes that the all five railway-line regions are at the stage of decentralization after 1980, and that the period of spatial sub-cycles for the Chuo-line region is approximately seven to ten years. This paper also mathematically compares the drawbacks and merits of three types of ROXY indices which are respectively set for (i) discrete-linear region, (ii) continuous-linear region and (iii) fan-shaped region. This study concludes that the ordinary definition of the ROXY index could be usable unless the distribution of the values of the weighing factors are extremely skewed toward either the smallest value or the largest value.

Key Words

Eigenvalue, Fan-shaped region, ROXY index, Spatial cycles, Suburbanization, Tokyo metropolitan area, Urbanization

* Hiraoka is associated with the National Infrastructure Department of Mitsubishi Research Institute in Tokyo, and Kawashima with the Economics Department of Gakushuin University in Tokyo. Kawashima gratefully acknowledges the research support from the Grant-in-Aid for General Scientific Research of the Ministry of Education, Science and Culture. Both authors are indebted to Masumi Morita for her diligent work in typing early versions of drafts.

Introduction

The major purpose of this paper is to investigate the mathematical characteristics of the ROXY index about the following two points; (i) the intra-metropolitan spatial-cycle paths and (ii) the theoretically-ideal formulations of the ROXY index. As to the first point, this paper examines a set of annual data for five railway-line regions in the Tokyo metropolitan area, through the ROXY index method. Based on the results of this examination, the present paper concludes that the all five railway-line regions are at the stage of decentralization in the 1980s, and that the period of sub-spatial cycles for the Chuo-line region is approximately seven to ten years in case we apply the values of the normalized three-year-averaged ROXY index. As to the second point, this paper mathematically compares the drawbacks and merits of each of the three types of ROXY indices which are respectively set for the cases of (i) discrete-linear region, (ii) continuous-liner region and (iii) fan-shaped region. Based on the results of this task, the present paper concludes that the ordinary definition of the ROXY index could be usable unless the distribution pattern of the values of the weighing factor is extremely skewed toward either its smallest value or its largest value. The possible future research agenda on the ROXY-index studies will be discussed in the last section.

Part I Periods of Intra-metropolitan Spatial Cycles

The purposes of Part I are twofold: (i) to calculate values of the ROXY index for the five railway-line regions (Chuo, Takasaki, Joban, Tokaido and Sobu railway-line regions) in the Tokyo metropolitan area by use of the annual population data (instead of National Census data which is published every five years), and (ii) to investigate the length of the period of the spatial-cycle paths by means of the eigenvalue approach.

1 Values of ROXY Index Based on Annual Data: For Five Railway-line Regions in Tokyo Metropolitan Area

Sources of the annual population data, which we employ in Part I, cover thirty years from 1963 through 1992, and are derived from the Resident Registration (*Juhmin Tohroku*) published by the Ministry of Justice for years 1963 to 1968 and from the Basic Resident Registers (*Juhmin Kihon Daicho*) by the Ministry of Home Affairs for years after 1969.

Tables 1 through 5 respectively show the distance, reversed distance and population for each locality in the Chuo-line, Takasaki-line, Joban-line, Tokaido-line, and Sobu-line regions¹⁾. From these tables we obtain Tables 6 through 10 respectively furnishing the annual growth ratio of population for each locality in the five regions. Based on these five tables, we get the values of ROXY index with reversed distance as weighting factor²⁾, as shown in Table 11 for the aggregated case and in Table 12 for the disaggregated case.

Mathematical Characteristics of ROXY Index (II): Periods of Intra-metropolitan
Spatial-cycle Paths and Theoretically-ideal Formulations of ROXY Index (Hiraoka, Kawashima)

Table 1 Distance and Population of Localities in Chuo-line Region

(Unit of distance : km, Unit of population : persons)

Code	Locality	Distance	Reversed distance in aggregated case	Reversed distance in disaggregated case	1963	1964	1965	1966	1967
13100	Tokyo-tokubetsu-kubu	7.4	55.5	—	8,424,426	8,526,620	8,587,099	8,675,167	8,694,866
13102	Chuo-ku	1.1	—	55.5	148,946	145,583	140,033	136,494	131,677
13101	Chiyoda-ku	2.1	—	54.5	116,384	111,593	105,752	102,957	100,134
13104	Shinjuku-ku	5.7	—	50.9	396,825	394,464	392,320	393,796	391,542
13113	Shibuya-ku	6.1	—	50.5	268,746	267,332	264,554	263,211	264,850
13114	Nakano-ku	9.6	—	47.0	353,272	353,694	351,447	357,227	360,134
13115	Suginami-ku	11.7	—	44.9	505,592	514,878	519,824	523,920	523,007
13203	Musashino-shi	18.5	44.4	38.1	127,636	129,389	131,061	132,807	132,343
13204	Witaka-shi	18.5	44.4	38.1	114,580	122,144	127,531	133,002	138,077
13210	Koganei-shi	23.7	39.2	32.9	60,231	67,202	73,051	77,674	81,107
13206	Puchu-shi	25.8	37.1	30.8	98,886	108,045	119,056	127,177	137,441
13214	Kokubunji-shi	27.5	35.4	29.1	48,594	53,481	59,898	65,516	68,545
13215	Kunitachi-shi	29.2	33.7	27.4	42,995	44,828	43,890	53,324	55,195
13202	Tachikawa-shi	31.0	31.9	25.6	92,698	98,657	101,212	102,012	106,503
13212	Hino-shi	33.2	29.7	23.4	52,621	57,627	64,548	70,404	76,372
13201	Hachioji-shi	40.3	22.6	16.3	173,893	183,109	205,413	214,450	211,924
14424	Pujino-mac	55.5	7.4	1.1	8,708	8,605	8,527	8,623	8,661

Table 1 (Continued)

1968	1969	1970	1971	1972	1973	1974	1975	1976	1977	1978	1979	1980
8,623,225	8,644,802	8,628,072	8,610,381	8,582,802	8,536,594	8,474,712	8,424,468	8,385,732	8,323,395	8,265,799	8,219,888	8,179,291
125,030	121,801	118,031	113,200	109,653	106,030	102,673	100,507	98,204	96,116	94,174	92,355	90,859
96,634	92,964	88,896	86,061	82,680	78,631	73,818	71,376	69,124	66,353	64,407	62,381	60,608
383,267	378,780	378,984	370,497	366,273	359,674	354,791	350,296	346,736	340,434	335,189	332,539	330,246
260,670	263,484	259,244	259,238	258,608	255,386	255,054	254,698	252,675	249,948	243,277	239,991	237,545
351,590	356,024	357,634	358,444	358,272	355,634	352,891	351,007	347,682	342,825	338,493	334,180	330,272
517,616	515,030	520,357	524,381	528,503	528,969	530,459	531,374	528,521	527,120	525,749	520,272	518,962
133,699	135,363	136,125	137,196	137,234	135,235	134,992	134,020	134,107	133,233	133,764	133,823	132,368
143,538	147,413	149,039	151,380	152,667	154,762	156,218	157,227	158,902	160,009	160,092	159,257	158,381
83,943	86,857	90,528	92,337	94,166	95,138	96,228	97,864	98,264	98,652	99,096	99,022	99,071
142,907	149,205	153,808	161,044	165,184	169,558	172,675	176,161	179,083	180,261	180,580	183,094	185,208
71,849	74,035	77,382	79,074	80,293	81,338	81,831	83,042	85,123	86,264	87,621	87,675	87,841
58,339	55,487	58,469	60,517	61,612	62,800	63,425	63,721	63,215	62,886	63,121	63,238	62,894
113,016	115,262	115,539	117,295	129,822	132,456	134,938	136,220	137,672	138,427	140,246	141,638	142,436
79,279	84,133	91,075	101,320	107,465	112,518	117,555	122,207	126,355	132,435	136,878	139,205	141,416
223,497	232,595	242,517	253,876	263,525	276,399	290,067	305,195	321,585	334,986	348,792	362,847	372,878
8,470	8,477	8,416	8,457	8,467	8,475	8,604	8,741	8,792	8,842	8,874	8,961	9,079

Table 1 (Continued)

1981	1982	1983	1984	1985	1986	1987	1988	1989	1990	1991	1992
8,152,336	8,138,581	8,150,673	8,170,379	8,194,973	8,216,250	8,209,067	8,155,781	8,098,663	8,046,160	8,006,386	7,975,817
90,491	89,434	88,959	88,265	88,396	86,447	84,789	81,933	79,594	77,325	75,898	74,976
59,911	59,263	58,360	57,337	56,735	55,032	53,349	51,074	48,941	47,442	46,240	44,233
328,294	327,680	327,230	324,689	322,182	321,270	315,815	308,603	300,682	291,564	284,205	276,622
235,501	233,252	233,958	232,781	232,714	231,411	226,713	219,237	210,988	203,933	197,447	191,774
327,219	324,460	325,572	323,634	323,538	322,391	320,905	316,471	311,347	308,104	305,098	303,020
516,201	515,492	516,446	516,952	519,145	522,134	521,521	518,611	514,867	512,573	510,848	511,223
131,587	132,004	132,620	137,656	134,469	135,433	135,865	135,429	134,732	134,959	134,477	134,136
158,126	159,025	158,851	160,214	159,971	161,293	161,222	161,845	161,012	160,399	160,410	161,293
98,424	98,394	99,131	99,766	100,427	100,926	101,367	100,781	101,244	101,341	102,391	103,301
186,202	187,777	189,459	192,493	194,411	197,632	200,236	201,193	201,900	203,119	204,385	206,138
88,230	88,492	89,376	90,572	92,589	96,697	98,096	96,865	97,307	97,802	98,895	99,383
62,794	62,999	63,636	63,707	63,791	64,206	64,398	64,183	64,050	64,185	64,601	65,023
141,848	142,169	142,975	143,951	145,321	147,648	149,662	150,601	151,653	152,172	152,694	153,669
142,798	144,671	147,122	149,312	150,976	153,656	155,953	157,116	157,876	159,910	160,607	161,212
380,748	388,414	398,843	405,243	412,076	418,433	425,412	432,731	438,645	447,887	455,269	462,722
9,598	9,907	10,015	10,071	10,033	10,061	10,126	10,256	10,440	10,589	10,777	10,949

Table 2 Distance and Population of Localities in Takasaki-line Region

(Unit of distance : km, Unit of population : persons)

Code	Locality	Distance	Reversed distance in aggregated case	Reversed distance in disaggregated case	1963	1964	1965	1966	1967
13100	Tokyo-tokubetsu-kubu	7.4	58.0	—	8,424,426	8,526,620	8,587,099	8,675,167	8,694,866
13106	Taito-ku	4.2	—	58.0	288,867	285,850	278,577	273,815	270,875
13118	Arakawa-ku	6.7	—	55.5	269,991	269,077	264,577	262,503	258,532
13117	Kita-ku	8.9	—	53.3	434,530	437,774	434,825	436,877	438,320
11203	Kawaguchi-shi	14.8	50.6	47.4	203,568	219,335	237,094	251,909	266,777
11223	Warabi-shi	18.0	47.4	44.2	59,199	62,866	65,489	67,421	71,349
11204	Urawa-shi	23.2	42.2	39.0	194,353	202,531	212,436	224,425	232,887
11220	Yono-shi	26.0	39.4	36.2	44,808	47,618	50,491	53,264	55,072
11205	Ohmiya-shi	28.0	37.4	34.2	192,132	201,681	211,992	221,738	231,303
11219	Ageo-shi	36.5	28.9	25.7	43,791	47,387	51,820	56,439	69,166
11231	Okegawa-shi	40.2	25.2	22.0	23,573	25,177	27,584	29,905	31,745
11233	Kitamoto-shi	44.0	21.4	18.2	16,845	17,938	19,492	21,394	24,345
11217	Kohnosu-shi	48.0	17.4	14.2	33,675	35,026	36,425	37,138	38,212
11304	Fukiage-machi	54.5	10.9	7.7	13,886	14,430	14,234	14,673	14,909
11206	Gyoda-shi	58.0	7.4	4.2	56,062	56,217	56,667	57,137	57,495

**Mathematical Characteristics of ROXY Index (II): Periods of Intra-metropolitan
Spatial-cycle Paths and Theoretically-ideal Formulations of ROXY Index (Hiraoka, Kawashima)**

Table 2 (Continued)

1968	1969	1970	1971	1972	1973	1974	1975	1976	1977	1978	1979	1980
8,623,225	8,644,802	8,628,072	8,610,381	8,582,802	8,536,594	8,474,712	8,424,468	8,385,732	8,323,395	8,265,799	8,219,888	8,179,291
262,726	254,242	242,056	236,179	228,964	222,503	215,813	209,449	205,429	199,828	195,026	190,869	187,502
251,002	246,165	240,966	235,141	228,538	222,497	215,562	211,094	207,890	203,204	198,944	196,396	193,047
432,574	426,909	424,096	418,689	417,592	413,022	415,789	412,166	408,139	404,316	398,641	391,804	384,215
277,620	288,759	298,247	306,398	314,924	322,168	327,686	336,710	343,833	349,793	354,691	366,449	374,128
73,566	74,778	76,264	76,359	76,617	76,137	75,538	75,019	74,129	72,918	71,914	70,520	69,651
243,306	252,499	261,692	273,411	286,244	300,437	315,021	324,289	333,392	339,490	343,832	349,293	353,293
56,161	57,604	59,914	62,173	64,106	66,554	67,907	68,873	69,913	70,676	70,916	71,081	70,703
242,128	250,880	261,946	274,112	288,670	302,647	315,074	324,021	331,495	337,804	340,311	344,097	348,316
76,826	90,315	102,984	114,620	123,654	131,387	137,582	142,026	147,136	152,021	155,725	159,989	164,306
33,462	36,171	38,490	40,355	42,263	43,790	45,348	47,351	48,658	50,576	52,269	53,847	55,069
26,260	28,266	30,730	32,534	38,268	41,876	43,800	45,961	47,181	47,882	49,228	49,843	50,426
39,054	40,416	41,525	42,818	44,236	45,760	48,387	50,683	52,197	53,713	54,888	55,667	56,420
15,542	16,089	16,672	17,503	17,932	18,211	18,488	18,592	18,829	19,335	19,865	20,836	21,760
58,672	59,386	60,184	61,162	62,160	63,225	64,441	65,702	67,083	68,439	69,622	71,143	72,872

Table 2 (Continued)

1981	1982	1983	1984	1985	1986	1987	1988	1989	1990	1991	1992
8,152,336	8,138,581	8,150,673	8,170,379	8,194,973	8,216,250	8,209,067	8,155,781	8,098,663	8,046,160	8,006,386	7,975,817
184,657	182,618	180,311	179,206	178,061	176,447	173,876	170,709	167,758	165,587	163,402	161,563
191,032	188,709	187,065	186,185	184,234	183,170	181,829	180,352	179,084	177,906	177,269	176,008
377,778	373,077	369,191	366,779	364,516	363,186	362,036	358,619	354,907	350,250	346,355	342,102
381,214	387,808	392,296	395,729	399,013	402,731	409,223	418,880	426,761	433,144	436,428	440,250
70,135	69,929	69,803	69,115	69,022	70,126	70,986	71,306	71,579	71,773	71,736	72,070
356,773	361,701	365,460	368,579	371,549	375,416	383,324	391,530	400,946	408,964	416,929	424,728
71,304	71,072	71,410	71,080	70,671	70,687	72,574	74,037	75,591	77,071	78,456	79,354
351,616	357,133	361,687	364,524	367,901	371,922	377,051	383,720	390,021	395,865	403,234	410,448
166,446	169,004	170,795	173,881	176,571	179,435	182,801	186,269	189,638	192,536	195,454	197,682
57,079	57,499	57,993	58,671	60,091	62,323	64,303	66,188	67,317	68,246	69,298	70,178
51,866	54,882	56,029	56,944	57,666	58,597	59,644	60,617	62,010	63,391	64,872	66,226
57,431	57,897	58,388	58,799	59,364	61,272	63,226	65,720	69,037	71,579	72,977	74,576
22,939	24,339	24,528	24,846	24,957	25,250	25,592	25,939	26,272	26,712	27,146	27,468
74,622	76,108	77,143	78,219	79,042	79,678	80,045	80,619	81,665	82,596	83,286	83,850

Table 3 Distance and Population of Localities in Joban-line Region

(Unit of distance : km, Unit of population : persons)

Code	Locality	Distance	Reversed distance in aggregated case	Reversed distance in disaggregated case	1963	1964	1965	1966	1967
13100	Tokyo-tokubetsu-kubu	7.4	48.0	—	8,424,426	8,526,620	8,587,099	8,675,167	8,694,866
13106	Taito-ku	4.2	—	48.0	288,867	285,850	278,577	273,815	270,875
13118	Arakawa-ku	6.7	—	45.5	269,991	269,077	264,577	262,503	258,532
13212	Adachi-ku	8.4	—	43.8	445,814	466,283	495,649	517,180	528,042
13122	Katsushika-ku	10.5	—	41.7	404,647	416,707	432,172	440,946	448,472
12207	Matsudo-shi	17.8	37.6	34.4	123,573	137,823	150,889	165,679	181,090
12220	Nagareyama-shi	23.5	31.9	28.7	32,183	35,421	38,092	40,399	43,445
12217	Kashiwa-shi	28.6	26.8	23.6	75,327	81,749	103,173	110,433	117,608
12222	Abiko-shi	31.7	23.7	20.5	29,608	31,180	32,870	34,675	36,177
8217	Toride-shi	36.5	18.9	15.7	23,436	24,289	25,669	26,937	28,552
8563	Fujishiro-machi	41.4	14.0	10.8	13,458	13,530	13,661	13,738	14,439
8208	Ryugasaki-shi	45.6	9.8	6.6	35,043	35,373	34,887	35,428	35,818
8219	Ushiku-shi	48.0	7.4	4.2	16,887	16,789	17,264	17,534	17,634

Table 3 (Continued)

1968	1969	1970	1971	1972	1973	1974	1975	1976	1977	1978	1979	1980
8,623,225	8,644,802	8,628,072	8,610,381	8,582,802	8,536,594	8,474,712	8,424,468	8,385,732	8,323,395	8,265,799	8,219,888	8,179,291
262,726	254,242	242,056	236,179	228,964	222,503	215,813	209,449	205,429	199,828	195,026	190,869	187,502
251,002	246,165	240,966	235,141	228,538	222,497	215,562	211,094	207,890	203,204	198,944	196,396	193,047
537,153	548,636	561,840	571,605	585,896	593,947	597,734	601,622	606,104	612,134	616,965	618,717	616,666
449,406	456,569	456,536	455,678	454,070	448,265	441,662	436,788	433,484	429,602	425,962	422,276	418,038
195,131	213,575	240,460	259,791	277,935	296,452	314,142	328,862	347,410	358,285	370,516	382,641	391,137
45,849	49,782	53,486	58,127	62,977	67,775	72,908	79,003	84,150	90,902	96,247	100,008	103,861
128,126	135,695	143,466	152,712	161,098	173,167	184,039	195,729	204,925	213,668	222,637	229,104	235,941
37,181	38,950	40,630	50,848	56,812	62,204	68,133	73,711	78,494	83,361	91,714	96,222	99,717
29,760	31,574	39,053	41,305	43,583	45,573	47,631	49,729	54,281	57,171	61,542	65,561	69,468
14,700	15,375	15,963	16,618	17,148	17,920	18,956	19,828	21,070	21,836	22,572	23,817	26,009
36,369	36,705	37,111	37,564	37,945	38,573	39,314	40,073	40,520	41,127	41,969	42,714	43,128
18,016	18,500	19,149	20,468	21,804	23,479	25,448	27,094	28,761	30,439	32,632	35,446	38,841

**Mathematical Characteristics of ROXY Index (II): Periods of Intra-metropolitan
Spatial-cycle Paths and Theoretically-ideal Formulations of ROXY Index (Hiraoka, Kawashima)**

Table 3 (Continued)

1981	1982	1983	1984	1985	1986	1987	1988	1989	1990	1991	1992
8,152,336	8,138,581	8,150,673	8,170,379	8,194,973	8,216,250	8,209,067	8,155,781	8,098,663	8,046,160	8,006.38	7,975,817
184,657	182,618	180,311	179,206	178,061	176,447	173,876	170,709	167,758	165,587	163,40	161,563
191,032	188,709	187,065	186,185	184,234	183,170	181,829	180,352	179,084	177,906	177,26	176,008
617,510	617,572	618,631	618,487	619,086	620,766	622,075	626,143	628,391	628,663	628,32	629,948
414,611	414,043	413,008	413,507	414,642	414,384	415,970	418,286	421,023	422,456	423,27	424,883
398,934	405,878	411,804	416,213	419,762	424,930	431,280	439,106	445,605	449,573	449,97	451,696
107,070	110,278	113,948	117,338	121,198	125,099	120,100	131,401	134,769	137,317	139,36	141,738
239,554	248,674	256,911	262,803	268,804	274,806	282,343	290,762	295,974	300,266	304,03	307,571
101,984	104,009	107,608	109,372	110,801	112,070	113,679	116,117	118,386	119,862	120,85	121,742
72,473	74,807	76,452	77,459	78,021	77,944	78,742	80,066	80,748	80,962	82,00	83,199
26,995	28,488	28,966	29,316	29,489	30,178	30,467	30,909	31,834	32,872	33,29	33,691
43,456	44,825	46,389	47,675	48,632	49,590	50,535	52,092	54,618	56,251	58,52	60,547
42,011	45,249	47,873	49,806	51,424	52,829	54,206	56,207	58,604	59,993	61,11	62,255

Table 4 Distance and Population of Localities in Tokaido-line Region

(Unit of distance : km, Unit of population : persons)

Code	Locality	Distance	Reversed distance in aggregated case	Reversed distance in disaggregated case	1963	1964	1965	1966	1967
13100	Tokyo-tokubetsu-kubu	7.4	50.1	—	8,424,426	8,526,620	8,587,099	8,675,167	8,694,866
13101	Chiyoda-ku	2.1	—	50.1	116,384	111,593	105,752	102,957	100,134
13103	Minato-ku	2.4	—	49.8	251,023	245,573	239,064	234,977	232,104
13109	Shinagawa-ku	8.1	—	44.1	415,126	415,540	412,170	409,239	401,339
13111	Ohta-ku	11.6	—	40.6	726,240	733,384	734,359	737,245	737,567
14130	Kawasaki-shi	17.2	40.3	—	737,201	768,185	813,531	844,128	870,687
14132	Saiwai-ku	15.6	—	36.6	—	—	—	—	—
14131	Kawasaki-ku	16.9	—	35.3	—	—	—	—	—
14100	Yokohama-shi	25.8	31.7	—	1,536,513	1,618,761	1,727,504	1,814,012	1,905,284
14101	Turumi-ku	19.8	—	32.4	236,385	237,524	240,091	242,326	252,346
14102	Kanagawa-ku	24.9	—	27.3	182,130	186,595	189,282	193,842	197,211
14103	Nishi-ku	27.6	—	24.6	114,028	113,681	107,824	107,272	106,835
14106	Hodogaya-ku	28.0	—	24.2	176,490	193,462	210,600	226,267	237,723
14110	Totsuka-ku	37.1	—	15.1	149,089	172,980	220,023	235,428	260,774
14204	Kamakura-shi	44.3	13.2	7.9	107,898	110,649	116,307	123,087	126,700
14205	Fujisawa-shi	44.9	12.6	7.3	145,650	152,587	170,717	187,252	197,095
14207	Chigasaki-shi	50.1	7.4	2.1	76,328	80,397	95,057	103,884	109,518

Table 4 (Continued)

1968	1969	1970	1971	1972	1973	1974	1975	1976	1977	1978	1979	1980
8,623,225	8,644,802	8,628,072	8,610,381	8,582,802	8,536,594	8,474,712	8,424,468	8,385,732	8,323,395	8,265,799	8,219,888	8,179,291
96,634	92,964	88,896	86,061	82,680	78,631	73,818	71,376	69,124	66,353	64,407	62,381	60,608
226,345	225,113	225,506	222,832	220,998	220,034	214,841	209,554	206,823	202,661	200,454	199,867	200,228
398,781	394,586	388,693	386,268	378,710	371,144	362,671	357,092	352,868	347,186	341,792	338,395	338,583
728,960	728,717	724,666	718,363	711,172	700,046	692,526	685,511	679,089	671,060	664,110	660,795	657,140
887,938	912,855	929,872	952,447	960,096	970,914	976,375	980,875	989,086	999,335	1,004,552	1,011,543	1,015,962
-	-	-	-	-	148,313	147,963	146,970	147,505	144,515	143,068	140,729	138,731
-	-	-	-	-	224,572	216,898	211,516	206,737	203,209	200,591	197,856	195,590
1,988,571	2,082,446	2,173,469	2,276,850	2,377,125	2,447,129	2,512,540	2,572,659	2,616,890	2,651,174	2,685,837	2,723,940	2,755,186
253,667	253,528	253,232	251,871	250,914	247,381	243,627	238,860	234,835	233,104	232,082	230,191	228,262
200,824	202,084	204,537	205,537	207,835	208,781	208,009	209,320	207,828	205,796	203,559	201,580	200,059
106,692	103,001	97,877	96,169	95,170	93,258	91,072	89,062	87,452	85,038	82,903	80,986	79,920
254,717	276,328	313,424	335,290	353,529	363,155	369,757	374,230	378,661	379,849	383,774	399,236	388,543
277,405	298,609	322,693	343,429	360,364	380,327	408,248	427,010	444,237	459,505	475,669	492,201	503,965
133,497	137,213	138,410	143,691	148,076	154,000	159,587	163,642	166,626	169,925	172,456	173,231	173,801
205,520	213,428	223,938	234,479	242,493	249,799	255,968	262,050	267,934	273,673	281,201	288,805	296,011
112,218	121,267	125,168	129,591	134,428	138,997	143,264	149,293	153,608	157,328	162,650	165,868	169,472

Table 4 (Continued)

1981	1982	1983	1984	1985	1986	1987	1988	1989	1990	1991	1992
8,152,336	8,138,581	8,150,673	8,170,379	8,194,973	8,216,250	8,209,067	8,155,781	8,098,663	8,046,160	8,006,386	7,975,817
59,911	59,263	58,360	57,337	56,735	55,032	53,349	51,074	48,941	47,442	46,240	44,233
200,927	200,466	200,636	197,889	195,850	191,739	186,072	177,288	170,660	164,755	159,369	154,683
338,661	337,872	338,304	343,377	348,541	350,826	348,007	343,387	339,827	335,508	331,178	327,914
654,145	654,989	655,646	657,132	658,827	659,414	658,539	653,989	650,741	648,322	654,229	642,592
1,020,480	1,027,136	1,039,356	1,049,460	1,061,084	1,077,817	1,095,873	1,114,173	1,127,952	1,139,622	1,152,639	1,161,936
137,282	135,646	135,851	135,468	136,226	137,441	138,469	140,989	141,715	141,107	140,533	140,409
194,302	193,198	192,675	191,306	190,412	190,879	191,433	192,121	193,927	194,034	195,245	195,783
2,787,487	2,823,192	2,867,902	2,915,220	2,959,692	3,012,884	3,071,987	3,121,601	3,152,742	3,175,989	3,210,607	3,233,127
226,861	227,108	228,804	228,601	231,536	233,044	236,760	239,272	244,231	247,109	249,292	250,594
198,522	197,749	197,569	198,615	199,294	199,960	201,510	201,399	200,768	200,369	203,710	204,155
78,818	78,442	77,883	77,635	77,521	77,751	77,265	76,583	76,206	75,516	76,669	76,042
392,627	398,619	404,012	410,554	412,608	419,225	425,109	431,597	435,646	439,585	443,829	445,686
511,556	520,779	531,288	543,628	553,749	563,227	573,862	588,024	599,189	606,702	611,883	618,573
174,884	175,408	175,804	176,878	176,456	176,569	177,143	177,372	176,682	176,163	175,539	175,527
303,347	308,876	314,369	318,830	323,626	328,485	333,064	336,892	341,303	344,835	347,648	350,820
172,939	176,281	179,416	181,476	183,631	186,582	190,689	194,764	197,336	200,754	202,553	205,099

Mathematical Characteristics of ROXY Index (II): Periods of Intra-metropolitan
Spatial-cycle Paths and Theoretically-ideal Formulations of ROXY Index (Hiraoka, Kawashima)

Table 5 Distance and Population of Localities in Sobu-line Region

(Unit of distance : km, Unit of population : persons)

Code	Locality	Distance	Reversed distance in aggregated case	Reversed distance in disaggregated case	1963	1964	1965	1966	1967
13100	Tokyo-tokubetsu-kubu	7.4	50.1	—	8,424,426	8,526,620	8,587,099	8,675,167	8,694,866
13101	Chiyoda-ku	2.1	—	49.8	116,384	111,593	105,752	102,957	100,134
13107	Sumida-ku	3.8	—	48.1	320,097	316,418	312,924	310,624	305,350
13106	Taito-ku	4.2	—	47.7	288,867	285,850	278,577	273,815	270,875
13108	Kohtoh-ku	4.9	—	47.0	344,156	345,816	341,926	341,355	335,189
13123	Edogawa-ku	10.0	—	41.9	348,057	368,534	389,441	407,551	421,172
13122	Katsushika-ku	10.5	—	41.4	404,647	416,707	432,172	440,946	448,472
12203	Ichikawa-shi	16.8	40.4	35.1	175,340	186,215	199,173	208,784	217,539
12204	Funabashi-shi	20.0	37.2	31.9	178,776	196,474	213,646	230,803	249,801
12216	Narashino-shi	24.0	33.2	27.9	51,173	56,858	62,391	66,675	69,246
12201	Chiba-shi	31.7	25.5	20.2	274,342	300,584	329,004	341,071	368,397
12228	Yotsukaido-shi	36.5	20.7	15.4	18,062	19,023	20,057	20,823	21,595
12212	Sakura-shi	41.7	15.5	10.2	37,808	38,970	40,528	42,911	45,684
12322	Shisui-machi	45.8	11.4	6.1	6,064	6,122	6,233	6,211	6,171
12323	Yachimata-machi	49.8	7.4	2.1	26,038	26,197	26,176	26,315	26,208

Table 5 (Continued)

1968	1969	1970	1971	1972	1973	1974	1975	1976	1977	1978	1979	1980
8,623,225	8,644,802	8,628,072	8,610,381	8,582,802	8,536,594	8,474,712	8,424,468	8,385,732	8,323,395	8,265,799	8,219,888	8,179,291
96,634	92,964	88,896	86,061	82,680	78,631	73,818	71,376	69,124	66,353	64,407	62,381	60,608
300,937	295,273	286,202	278,527	270,901	263,850	256,763	253,998	250,010	244,760	240,079	236,988	234,514
262,726	254,242	242,056	236,179	228,964	222,503	215,813	209,449	205,429	199,828	195,026	190,869	187,502
327,372	336,989	344,537	350,042	353,670	350,743	349,553	346,664	346,629	346,618	349,403	349,710	353,589
432,006	440,649	445,788	454,187	458,597	463,412	465,328	471,944	472,646	479,859	482,924	486,627	492,753
449,406	456,569	456,536	455,678	454,070	448,265	441,662	436,788	433,484	429,602	425,962	422,276	418,038
235,226	238,358	246,883	258,298	268,447	277,318	287,532	300,732	314,738	325,771	336,781	343,893	350,884
270,937	288,118	312,445	329,227	351,898	373,963	392,505	406,965	416,256	426,945	441,826	455,883	467,739
85,274	90,769	95,740	101,632	105,348	108,001	111,694	114,728	117,177	117,853	118,436	118,837	120,508
390,746	424,188	471,086	494,870	518,401	549,371	589,348	629,842	660,602	681,956	700,007	718,225	732,070
22,174	23,809	25,533	27,179	28,757	31,159	33,488	36,232	40,456	45,460	50,427	55,653	58,593
49,221	54,104	58,914	63,748	68,243	73,022	77,519	80,972	83,135	86,182	91,022	95,176	99,616
6,020	6,315	6,381	6,550	6,783	6,961	7,353	8,244	8,859	9,189	9,722	10,723	12,327
25,013	25,698	25,821	25,990	26,445	27,134	27,843	28,472	29,014	29,806	30,508	31,095	31,721

Table 5 (Continued)

1981	1982	1983	1984	1985	1986	1987	1988	1989	1990	1991	1992
8,152,336	8,138,581	8,150,673	8,170,379	8,194,973	8,216,250	8,209,067	8,155,781	8,098,663	8,046,160	8,006,386	7,975,817
59,911	59,263	58,360	57,337	56,735	55,032	53,349	51,074	48,941	47,442	46,240	44,233
233,011	232,162	233,041	232,183	231,274	229,807	228,413	227,131	224,785	223,490	222,315	220,649
184,657	182,618	180,311	179,206	178,061	176,447	173,876	170,709	167,758	165,587	163,402	161,563
358,260	367,798	373,871	377,515	381,229	385,080	387,280	386,895	384,127	380,895	376,690	375,121
495,851	496,325	498,160	504,348	511,707	519,564	531,349	539,228	548,720	557,078	565,935	573,866
414,611	414,043	413,008	413,507	414,642	414,384	415,970	418,286	421,023	422,456	423,272	424,883
360,784	368,731	375,668	382,145	388,902	397,169	404,820	412,214	418,759	422,795	427,920	433,330
475,424	482,347	488,867	494,654	497,512	501,981	507,708	515,295	521,519	524,699	524,921	527,402
125,043	128,873	130,805	131,903	132,608	134,732	138,006	142,535	145,304	147,426	148,900	149,704
743,314	749,074	757,285	767,695	777,021	784,811	792,870	800,620	809,128	815,552	821,003	825,303
60,813	62,500	63,877	65,728	66,256	67,271	68,200	69,576	70,785	71,764	72,717	73,922
104,276	108,914	113,555	116,972	120,459	123,251	127,002	132,297	138,411	143,070	147,303	151,222
13,422	15,552	16,401	17,108	17,362	17,578	17,977	18,324	19,101	19,418	19,694	19,855
32,560	33,676	35,035	36,121	37,262	38,435	40,112	42,641	45,326	48,433	51,198	54,356

Table 6 Growth Ratio of Localities in Chuo-line Region

Code	Locality	1963-64	1964-65	1965-66	1966-67	1967-68	1968-69	1969-70	1970-71	1971-72	1972-73	1973-74	1974-75	1975-76	1976-77
13100	Tokyo-tokubetsu-kubu	1.0121	1.0071	1.0103	1.0023	0.9918	1.0025	0.9981	0.9979	0.9968	0.9946	0.9928	0.9941	0.9954	0.9926
13102	Chuo-ku	0.9774	0.9619	0.9747	0.9647	0.9495	0.9742	0.9690	0.9591	0.9687	0.9670	0.9683	0.9789	0.9771	0.9787
13101	Chiyoda-ku	0.9588	0.9477	0.9736	0.9726	0.9650	0.9620	0.9562	0.9681	0.9607	0.9510	0.9388	0.9669	0.9684	0.9599
13104	Shinjuku-ku	0.9941	0.9946	1.0038	0.9943	0.9789	0.9883	1.0005	0.9776	0.9886	0.9820	0.9864	0.9873	0.9898	0.9818
13113	Shibuya-ku	0.9947	0.9896	0.9949	1.0062	0.9842	1.0108	0.9839	1.0000	0.9976	0.9875	0.9987	0.9986	0.9921	0.9892
13114	Nakano-ku	1.0012	0.9936	1.0164	1.0081	0.9763	1.0126	1.0045	1.0023	0.9995	0.9926	0.9923	0.9947	0.9905	0.9860
13115	Suginami-ku	1.0184	1.0096	1.0079	0.9983	0.9897	0.9950	1.0103	1.0077	1.0079	1.0009	1.0028	1.0017	0.9946	0.9973
13203	Musashino-shi	1.0137	1.0129	1.0133	0.9965	1.0102	1.0124	1.0056	1.0079	1.0003	0.9854	0.9982	0.9928	1.0006	0.9935
13204	Mitaka-shi	1.0660	1.0441	1.0429	1.0382	1.0396	1.0270	1.0110	1.0157	1.0085	1.0137	1.0094	1.0065	1.0107	1.0070
13210	Koganei-shi	1.1157	1.0870	1.0633	1.0442	1.0350	1.0347	1.0423	1.0200	1.0198	1.0103	1.0115	1.0170	1.0041	1.0039
13206	Fuchu-shi	1.0926	1.1019	1.0682	1.0807	1.0398	1.0441	1.0309	1.0470	1.0257	1.0265	1.0184	1.0202	1.0166	1.0066
13214	Kokubunji-shi	1.1006	1.1200	1.0938	1.0462	1.0482	1.0304	1.0452	1.0219	1.0154	1.0130	1.0061	1.0148	1.0251	1.0134
13215	Kunitachi-shi	1.0426	0.9791	1.2149	1.0351	1.0570	0.9511	1.0537	1.0350	1.0181	1.0193	1.0100	1.0047	0.9921	0.9948
13202	Tachikawa-shi	1.0643	1.0259	1.0079	1.0440	1.0612	1.0199	1.0024	1.0152	1.1068	1.0203	1.0187	1.0095	1.0107	1.0055
13212	Hino-shi	1.0951	1.1201	1.0907	1.0848	1.0381	1.0612	1.0825	1.1125	1.0606	1.0470	1.0448	1.0396	1.0339	1.0481
13201	Hachioji-shi	1.0530	1.1218	1.0440	0.9882	1.0546	1.0407	1.0427	1.0468	1.0380	1.0489	1.0495	1.0522	1.0537	1.0417
14424	Fujino-machi	0.9882	0.9909	1.0113	1.0044	0.9779	1.0008	0.9928	1.0049	1.0012	1.0009	1.0152	1.0159	1.0058	1.0057

**Mathematical Characteristics of ROXY Index (II): Periods of Intra-metropolitan
Spatial-cycle Paths and Theoretically-ideal Formulations of ROXY Index (Hiraoka, Kawashima)**

Table 6 (Continued)

1977-78	1978-79	1979-80	1980-81	1981-82	1982-83	1983-84	1984-85	1985-86	1986-87	1987-88	1988-89	1989-90	1990-91	1991-92
0.9931	0.9944	0.9951	0.9967	0.9983	1.0015	1.0024	1.0030	1.0026	0.9991	0.9935	0.9930	0.9935	0.9951	0.9962
0.9798	0.9807	0.9838	0.9959	0.9883	0.9947	0.9922	1.0015	0.9780	0.9808	0.9683	0.9715	0.9715	0.9815	0.9879
0.9707	0.9685	0.9716	0.9885	0.9892	0.9848	0.9825	0.9895	0.9700	0.9694	0.9574	0.9582	0.9694	0.9747	0.9566
0.9846	0.9921	0.9931	0.9941	0.9981	0.9986	0.9922	0.9923	0.9972	0.9830	0.9772	0.9743	0.9697	0.9748	0.9733
0.9733	0.9865	0.9898	0.9914	0.9905	1.0030	0.9950	0.9997	0.9944	0.9797	0.9670	0.9624	0.9668	0.9682	0.9713
0.9874	0.9873	0.9883	0.9908	0.9916	1.0034	0.9940	0.9997	0.9965	0.9954	0.9862	0.9838	0.9896	0.9902	0.9932
0.9974	0.9896	0.9975	0.9947	0.9986	1.0019	1.0010	1.0042	1.0058	0.9988	0.9944	0.9928	0.9955	0.9966	1.0007
1.0040	1.0004	0.9891	0.9941	1.0032	1.0047	1.0380	0.9768	1.0072	1.0032	0.9668	0.9949	1.0017	0.9964	0.9975
1.0005	0.9948	0.9945	0.9984	1.0057	0.9989	1.0086	0.9985	1.0083	0.9996	1.0039	0.9949	0.9962	1.0001	1.0055
1.0045	0.9993	1.0005	0.9935	0.9997	1.0075	1.0064	1.0066	1.0050	1.0044	0.9942	1.0046	1.0010	1.0104	1.0089
1.0018	1.0139	1.0115	1.0054	1.0085	1.0090	1.0160	1.0100	1.0166	1.0132	1.0048	1.0035	1.0060	1.0062	1.0086
1.0157	1.0006	1.0019	1.0044	1.0030	1.0100	1.0134	1.0223	1.0444	1.0145	0.9875	1.0046	1.0051	1.0112	1.0049
1.0037	1.0019	0.9946	0.9984	1.0033	1.0101	1.0011	1.0013	1.0065	1.0030	0.9967	0.9979	1.0021	1.0065	1.0065
1.0131	1.0099	1.0056	0.9959	1.0023	1.0057	1.0068	1.0095	1.0160	1.0136	1.0063	1.0070	1.0034	1.0034	1.0064
1.0335	1.0170	1.0159	1.0098	1.0131	1.0169	1.0149	1.0111	1.0178	1.0149	1.0075	1.0048	1.0129	1.0044	1.0038
1.0412	1.0403	1.0276	1.0211	1.0201	1.0269	1.0160	1.0169	1.0154	1.0167	1.0172	1.0137	1.0211	1.0165	1.0164
1.0036	1.0098	1.0132	1.0572	1.0322	1.0109	1.0056	0.9962	1.0028	1.0065	1.0128	1.0179	1.0143	1.0178	1.0160

Table 7 Growth Ratio of Localities in Takasaki-line Region

Code	Locality	1963-64	1964-65	1965-66	1966-67	1967-68	1968-69	1969-70	1970-71	1971-72	1972-73	1973-74	1974-75	1975-76	1976-77
13100	Tokyo-tokubetsu-kubu	1.0121	1.0071	1.0103	1.0023	0.9918	1.0025	0.9981	0.9979	0.9968	0.9946	0.9928	0.9941	0.9954	0.9926
13106	Taito-ku	0.9896	0.9746	0.9829	0.9883	0.9699	0.9677	0.9521	0.9757	0.9695	0.9718	0.9699	0.9705	0.9808	0.9727
13118	Arakawa-ku	0.9966	0.9833	0.9922	0.9849	0.9709	0.9807	0.9789	0.9758	0.9719	0.9736	0.9688	0.9793	0.9848	0.9775
13117	Kita-ku	1.0075	0.9933	1.0047	1.0033	0.9869	0.9869	0.9934	0.9872	0.9974	0.9891	1.0067	0.9913	0.9902	0.9906
11203	Kawaguchi-shi	1.0775	1.0810	1.0625	1.0590	1.0406	1.0401	1.0329	1.0273	1.0278	1.0230	1.0171	1.0275	1.0212	1.0173
11223	Warabi-shi	1.0619	1.0417	1.0295	1.0583	1.0311	1.0165	1.0199	1.0012	1.0034	0.9937	0.9921	0.9931	0.9881	0.9837
11204	Urawa-shi	1.0421	1.0489	1.0564	1.0377	1.0447	1.0378	1.0364	1.0448	1.0469	1.0496	1.0485	1.0294	1.0281	1.0183
11220	Yono-shi	1.0627	1.0603	1.0549	1.0339	1.0198	1.0257	1.0401	1.0377	1.0311	1.0382	1.0203	1.0142	1.0151	1.0109
11205	Ohmiya-shi	1.0497	1.0511	1.0460	1.0431	1.0468	1.0361	1.0441	1.0464	1.0531	1.0484	1.0411	1.0284	1.0231	1.0190
11219	Ageo-shi	1.0821	1.0935	1.0891	1.2255	1.1107	1.1756	1.1403	1.1130	1.0788	1.0625	1.0472	1.0323	1.0360	1.0332
11231	Okogawa-shi	1.0680	1.0956	1.0841	1.0615	1.0541	1.0810	1.0641	1.0485	1.0473	1.0361	1.0356	1.0442	1.0276	1.0394
11233	Kitamoto-shi	1.0649	1.0866	1.0976	1.1379	1.0787	1.0764	1.0872	1.0587	1.1762	1.0943	1.0459	1.0493	1.0265	1.0149
11217	Kohnosu-shi	1.0401	1.0399	1.0196	1.0289	1.0220	1.0349	1.0274	1.0311	1.0331	1.0345	1.0574	1.0475	1.0299	1.0290
11304	Fukiage-machi	1.0392	0.9864	1.0308	1.0161	1.0425	1.0352	1.0362	1.0498	1.0245	1.0156	1.0152	1.0056	1.0127	1.0269
11206	Gyoda-shi	1.0028	1.0080	1.0083	1.0063	1.0205	1.0122	1.0134	1.0163	1.0163	1.0171	1.0192	1.0196	1.0210	1.0202

Table 7 (Continued)

1977-78	1978-79	1979-80	1980-81	1981-82	1982-83	1983-84	1984-85	1985-86	1986-87	1987-88	1988-89	1989-90	1990-91	1991-92
0.9931	0.9944	0.9951	0.9967	0.9983	1.0015	1.0024	1.0030	1.0026	0.9991	0.9935	0.9930	0.9935	0.9951	0.9962
0.9760	0.9787	0.9824	0.9848	0.9890	0.9874	0.9939	0.9936	0.9909	0.9854	0.9818	0.9827	0.9871	0.9868	0.9887
0.9790	0.9872	0.9829	0.9896	0.9878	0.9913	0.9953	0.9895	0.9942	0.9927	0.9919	0.9930	0.9934	0.9964	0.9929
0.9860	0.9828	0.9806	0.9832	0.9876	0.9896	0.9935	0.9938	0.9964	0.9968	0.9906	0.9896	0.9869	0.9889	0.9877
1.0140	1.0331	1.0210	1.0189	1.0173	1.0116	1.0088	1.0083	1.0093	1.0161	1.0236	1.0188	1.0150	1.0076	1.0088
0.9862	0.9806	0.9877	1.0069	0.9971	0.9982	0.9901	0.9987	1.0160	1.0123	1.0045	1.0038	1.0027	0.9995	1.0047
1.0128	1.0159	1.0115	1.0099	1.0138	1.0104	1.0085	1.0081	1.0104	1.0211	1.0214	1.0240	1.0200	1.0195	1.0187
1.0034	1.0023	0.9947	1.0085	0.9967	1.0048	0.9954	0.9942	1.0002	1.0267	1.0202	1.0210	1.0196	1.0180	1.0114
1.0074	1.0111	1.0123	1.0095	1.0157	1.0128	1.0078	1.0093	1.0109	1.0138	1.0177	1.0164	1.0150	1.0186	1.0179
1.0244	1.0274	1.0270	1.0130	1.0154	1.0106	1.0181	1.0155	1.0162	1.0188	1.0190	1.0181	1.0153	1.0152	1.0114
1.0335	1.0302	1.0227	1.0365	1.0074	1.0086	1.0117	1.0242	1.0371	1.0318	1.0293	1.0171	1.0138	1.0154	1.0127
1.0281	1.0125	1.0117	1.0286	1.0581	1.0209	1.0163	1.0127	1.0161	1.0179	1.0163	1.0230	1.0223	1.0234	1.0209
1.0219	1.0142	1.0135	1.0179	1.0081	1.0085	1.0070	1.0096	1.0321	1.0319	1.0394	1.0505	1.0368	1.0195	1.0219
1.0274	1.0489	1.0443	1.0542	1.0610	1.0078	1.0130	1.0045	1.0117	1.0135	1.0136	1.0128	1.0167	1.0162	1.0119
1.0173	1.0218	1.0243	1.0240	1.0199	1.0136	1.0139	1.0105	1.0080	1.0046	1.0072	1.0130	1.0114	1.0084	1.0068

Table 8 Growth Ratio of Localities in Joban-line Region

Code	Locality	1963-64	1964-65	1965-66	1966-67	1967-68	1968-69	1969-70	1970-71	1971-72	1972-73	1973-74	1974-75	1975-76	1976-77
13100	Tokyo-tokubetsu-kubu	1.0121	1.0071	1.0103	1.0023	0.9918	1.0025	0.9981	0.9979	0.9968	0.9946	0.9928	0.9941	0.9954	0.9926
13106	Taito-ku	0.9896	0.9746	0.9829	0.9893	0.9699	0.9677	0.9521	0.9757	0.9695	0.9718	0.9699	0.9705	0.9808	0.9727
13118	Arakawa-ku	0.9966	0.9833	0.9922	0.9849	0.9709	0.9807	0.9789	0.9758	0.9719	0.9736	0.9688	0.9793	0.9848	0.9775
13212	Adachi-ku	1.0459	1.0630	1.0434	1.0210	1.0173	1.0214	1.0241	1.0174	1.0250	1.0137	1.0064	1.0085	1.0074	1.0099
13122	Katsushika-ku	1.0298	1.0371	1.0203	1.0171	1.0021	1.0159	0.9999	0.9981	0.9965	0.9872	0.9853	0.9890	0.9924	0.9910
12207	Matsudo-shi	1.1153	1.0948	1.0980	1.0930	1.0775	1.0945	1.1259	1.0804	1.0698	1.0666	1.0597	1.0489	1.0564	1.0313
12220	Nagareyama-shi	1.1006	1.0754	1.0606	1.0754	1.0553	1.0858	1.0744	1.0868	1.0834	1.0762	1.0757	1.0836	1.0651	1.0802
12217	Kashiwa-shi	1.0853	1.2621	1.0704	1.0650	1.0894	1.0591	1.0573	1.0644	1.0549	1.0749	1.0628	1.0635	1.0470	1.0427
12222	Abiko-shi	1.0531	1.0542	1.0549	1.0433	1.0278	1.0476	1.0431	1.2515	1.1173	1.0949	1.0953	1.0819	1.0649	1.0620
8217	Toride-shi	1.0364	1.0568	1.0494	1.0600	1.0423	1.0610	1.2369	1.0577	1.0552	1.0457	1.0452	1.0440	1.0915	1.0532
8563	Fujishiro-machi	1.0053	1.0097	1.0056	1.0510	1.0181	1.0459	1.0382	1.0410	1.0319	1.0450	1.0578	1.0460	1.0626	1.0364
8208	Ryugasaki-shi	1.0094	0.9863	1.0155	1.0110	1.0154	1.0092	1.0111	1.0122	1.0101	1.0166	1.0192	1.0193	1.0112	1.0150
8219	Ushiku-shi	0.9942	1.0283	1.0156	1.0057	1.0217	1.0289	1.0351	1.0689	1.0653	1.0768	1.0839	1.0647	1.0615	1.0583

Mathematical Characteristics of ROXY Index (II): Periods of Intra-metropolitan
Spatial-cycle Paths and Theoretically-ideal Formulations of ROXY Index (Hiraoka, Kawashima)

Table 8 (Continued)

1977-78	1978-79	1979-80	1980-81	1981-82	1982-83	1983-84	1984-85	1985-86	1986-87	1987-88	1988-89	1989-90	1990-91	1991-92
0.9931	0.9944	0.9951	0.9967	0.9983	1.0015	1.0024	1.0030	1.0026	0.9991	0.9935	0.9930	0.9935	0.9951	0.9962
0.9760	0.9787	0.9824	0.9848	0.9890	0.9874	0.9939	0.9936	0.9909	0.9854	0.9818	0.9827	0.9871	0.9868	0.9887
0.9790	0.9872	0.9829	0.9896	0.9878	0.9913	0.9953	0.9895	0.9942	0.9927	0.9919	0.9930	0.9934	0.9964	0.9929
1.0079	1.0028	0.9967	1.0014	1.0001	1.0017	0.9938	1.0010	1.0027	1.0021	0.0065	1.0036	1.0004	0.9995	1.0026
0.9915	0.9913	0.9900	0.9918	0.9986	1.9975	1.0012	1.0027	0.9994	1.0038	1.0056	1.0065	1.0034	1.0019	1.0038
1.0341	1.0327	1.0222	1.0199	1.0174	1.0146	1.0107	1.0085	1.0123	1.0149	1.0181	1.0148	1.0089	1.0009	1.0038
1.0588	1.0391	1.0385	1.0309	1.0300	1.0333	1.0298	1.0329	1.0322	0.9600	1.0941	1.0256	1.0189	1.0149	1.0170
1.0420	1.0290	1.0298	1.0153	1.0381	1.0331	1.0229	1.0228	1.0223	1.0274	1.0298	1.0179	1.0145	1.0125	1.0116
1.1002	1.0492	1.0363	1.0227	1.0199	1.0346	1.0164	1.0131	1.0115	1.0144	1.0214	1.0195	1.0125	1.0083	1.0074
1.0765	1.0653	1.0596	1.0433	1.0322	1.0220	1.0132	1.0073	0.9990	1.0102	1.0168	1.0085	1.0027	1.0129	1.0145
1.0337	1.0552	1.0920	1.0379	1.0553	1.0168	1.0121	1.0059	1.0234	1.0096	1.0145	1.0299	1.0326	1.0127	1.0120
1.0205	1.0178	1.0097	1.0076	1.0315	1.0349	1.0277	1.0201	1.0197	1.0191	1.0308	1.0485	1.0299	1.0405	1.0345
1.0720	1.0862	1.0958	1.0816	1.0771	1.0580	1.0404	1.0325	1.0273	1.0261	1.0369	1.0426	1.0237	1.0187	1.0186

Table 9 Growth Ratio of Localities in Tokaido-line Region

Code	Locality	1963-64	1964-65	1965-66	1966-67	1967-68	1968-69	1969-70	1970-71	1971-72	1972-73	1973-74	1974-75	1975-76	1976-77
13100	Tokyo-tokubetsu-kubu	1.0121	1.0071	1.0103	1.0023	0.9918	1.0025	0.9981	0.9979	0.9968	0.9946	0.9928	0.9941	0.9954	0.9926
13101	Chiyoda-ku	0.9588	0.9477	0.9736	0.9726	0.9650	0.9620	0.9562	0.9681	0.9607	0.9510	0.9388	0.9669	0.9684	0.9599
13103	Minato-ku	0.9783	0.9735	0.9829	0.9878	0.9752	0.9946	1.0017	0.9881	0.9918	0.9956	0.9764	0.9754	0.9870	0.9799
13109	Shinagawa-ku	1.0010	0.9919	0.9929	0.9807	0.9936	0.9895	0.9851	0.9938	0.9804	0.9800	0.9772	0.9846	0.9882	0.9839
13111	Ohta-ku	1.0098	1.0013	1.0039	1.0004	0.9883	0.9997	0.9944	0.9913	0.9900	0.9844	0.9893	0.9899	0.9906	0.9882
14130	Kawasaki-shi	1.0420	1.0590	1.0376	1.0315	1.0198	1.0278	1.0189	1.0243	1.0080	1.0113	1.0056	1.0046	1.0084	1.0104
14132	Saiwai-ku	1.0420	1.0590	1.0376	1.0315	1.0198	1.0278	1.0189	1.0243	1.0080	1.0113	0.9976	0.9933	1.0036	0.9797
14131	Kawasaki-ku	1.0420	1.0590	1.0376	1.0315	1.0198	1.0278	1.0189	1.0243	1.0080	1.0113	0.9658	0.9752	0.9774	0.9829
14100	Yokohama-shi	1.0535	1.0672	1.0501	1.0503	1.0437	1.0472	1.0437	1.0476	1.0440	1.0294	1.0267	1.0239	1.0172	1.0131
14101	Turumi-ku	1.0048	1.0108	1.0093	1.0413	1.0052	0.9995	0.9988	0.9946	0.9962	0.9859	0.9848	0.9804	0.9831	0.9926
14102	Kanagawa-ku	1.0245	1.0144	1.0241	1.0174	1.0183	1.0063	1.0121	1.0049	1.0112	1.0046	0.9963	1.0063	0.9929	0.9902
14103	Nishi-ku	0.9970	0.9485	0.9949	0.9959	0.9987	0.9854	0.9503	0.9825	0.9896	0.9799	0.9766	0.9779	0.9819	0.9724
14106	Hodogaya-ku	1.0962	1.0886	1.0744	1.0506	1.0715	1.0848	1.1342	1.0698	1.0544	1.0272	1.0182	1.0121	1.0118	1.0031
14110	Totsuka-ku	1.1602	1.2720	1.0700	1.1077	1.0638	1.0764	1.0807	1.0643	1.0493	1.0554	1.0734	1.0460	1.0403	1.0344
14204	Kamakura-shi	1.0255	1.0511	1.0583	1.0294	1.0536	1.0278	1.0087	1.0382	1.0305	1.0400	1.0363	1.0254	1.0182	1.0198
14205	Fujisawa-shi	1.0476	1.1188	1.0969	1.0526	1.0427	1.0385	1.0492	1.0471	1.0342	1.0301	1.0247	1.0238	1.0225	1.0214
14207	Chigasaki-shi	1.0533	1.1823	1.0929	1.0542	1.0247	1.0806	1.0322	1.0353	1.0373	1.0340	1.0307	1.0421	1.0289	1.0242

Table 9 (Continued)

1977-78	1978-79	1979-80	1980-81	1981-82	1982-83	1983-84	1984-85	1985-86	1986-87	1987-88	1988-89	1989-90	1990-91	1991-92
0.9931	0.9944	0.9951	0.9967	0.9983	1.0015	1.0024	1.0030	1.0026	0.9991	0.9935	0.9930	0.9935	0.9951	0.9962
0.9707	0.9685	0.9716	0.9885	0.9892	0.9848	0.9825	0.9895	0.9700	0.9694	0.9574	0.9582	0.9694	0.9747	0.9566
0.9891	0.9971	1.0018	1.0035	0.9977	1.0008	0.9863	0.9897	0.9790	0.9704	0.9528	0.9626	0.9654	0.9673	0.9706
0.9845	0.9901	1.0006	1.0002	0.9977	1.0013	1.0150	1.0150	1.0066	0.9920	0.9867	0.9896	0.9873	0.9871	0.9901
0.9896	0.9950	0.9945	0.9954	1.0013	1.0010	1.0023	1.0026	1.0009	1.9987	0.9931	0.9950	0.9963	0.9520	0.9959
1.0052	1.0070	1.0044	1.0044	1.0065	1.0119	1.0097	1.0111	1.0158	1.0168	1.0167	1.0103	1.0103	1.0114	1.0081
0.9900	0.9837	0.9858	0.9896	0.9881	1.0015	0.9972	1.0056	1.0089	1.0075	1.0182	1.0051	0.9957	0.9959	1.9991
0.9871	0.9864	0.9885	0.9934	0.9943	0.9973	0.9929	0.9953	1.0025	1.0029	1.0036	1.0094	1.0006	1.0062	1.0028
1.0131	1.0142	1.0115	1.0117	1.0128	1.0158	1.0165	1.0153	1.0180	1.0196	1.0162	1.0100	1.0074	1.0109	1.0070
0.9956	0.9914	0.9916	0.9939	1.0011	1.0075	0.9991	1.0128	1.0065	1.0159	1.0106	1.0207	1.0118	1.0088	1.0052
0.9891	0.9903	0.9925	0.9923	0.9961	0.9991	1.0053	1.0034	1.0033	1.0078	0.9994	0.9969	0.9980	1.0067	1.0022
0.9749	0.9769	0.9868	0.9862	0.9952	0.9929	0.9968	0.9985	1.0030	0.9937	0.9912	0.9951	0.9909	1.0153	0.9918
1.0103	1.0403	0.9732	1.0105	1.0153	1.0135	1.0162	1.0050	1.0160	1.0140	1.0153	1.0094	1.0090	1.0097	1.0042
1.0352	1.0348	1.0239	1.0151	1.0180	1.0202	1.0232	1.0186	1.0171	1.0189	1.0247	1.0190	1.0125	1.0085	1.0109
1.0149	1.0045	1.0033	1.0062	1.0030	1.0023	1.0061	0.9976	1.0006	1.0033	1.0013	0.9961	0.9971	0.9965	0.9999
1.0275	1.0270	1.0250	1.0248	1.0182	1.0178	1.0142	1.0150	1.0150	1.0139	1.0115	1.0131	1.0103	1.0082	1.0091
1.0338	1.0198	1.0217	1.0205	1.0193	1.0178	1.0115	1.0119	1.0161	1.0220	1.0214	1.0132	1.0173	1.0090	1.0126

Table 10 Growth Ratio of Localities in Sobu-line Region

Code	Locality	1963-64	1964-65	1965-66	1966-67	1967-68	1968-69	1969-70	1970-71	1971-72	1972-73	1973-74	1974-75	1975-76	1976-77
13100	Tokyo-tokubetsu-kubu	1.0121	1.0071	1.0103	1.0023	0.9918	1.0025	0.9981	0.9979	0.9968	0.9946	0.9928	0.9941	0.9954	0.9926
13101	Chiyoda-ku	0.9588	0.9477	0.9736	0.9726	0.9650	0.9620	0.9562	0.9681	0.9607	0.9510	0.9388	0.9669	0.9684	0.9599
13107	Sumida-ku	0.9885	0.9890	0.9926	0.9830	0.9855	0.9812	0.9693	0.9732	0.9726	0.9740	0.9731	0.9892	0.9843	0.9790
13106	Taito-ku	0.9896	0.9746	0.9829	0.9893	0.9699	0.9677	0.9521	0.9757	0.9695	0.9718	0.9699	0.9705	0.9808	0.9727
13108	Kohtoh-ku	1.0048	0.9888	0.9983	0.9819	0.9767	1.0294	1.0224	1.0160	1.0104	0.9917	0.9966	0.9917	0.9999	1.0000
13123	Edogawa-ku	1.0588	1.0567	1.0465	1.0334	1.0257	1.0200	1.0117	1.0188	1.0097	1.0105	1.0041	1.0142	1.0015	1.0153
13122	Katsushika-ku	1.0298	1.0371	1.0203	1.0171	1.0021	1.0159	0.9999	0.9981	0.9965	0.9872	0.9853	0.9890	0.9924	0.9910
12203	Ichikawa-shi	1.0620	1.0696	1.0483	1.0419	1.0813	1.0133	1.0358	1.0462	1.0393	1.0330	1.0368	1.0459	1.0466	1.0351
12204	Funabashi-shi	1.0990	1.0874	1.0803	1.0823	1.0846	1.0634	1.0844	1.0537	1.0689	1.0627	1.0496	1.0368	1.0228	1.0257
12216	Narashino-shi	1.1111	1.0973	1.0687	1.0386	1.2315	1.0644	1.0548	1.0615	1.0366	1.0252	1.0342	1.0272	1.0213	1.0058
12201	Chiba-shi	1.0957	1.0945	1.0367	1.0801	1.0607	1.0855	1.1106	1.0505	1.0475	1.0597	1.0728	1.0687	1.0488	1.0323
12228	Yotsukaido-shi	1.0532	1.0544	1.0382	1.0371	1.0268	1.0737	1.0724	1.0645	1.0581	1.0835	1.0747	1.0819	1.1166	1.1237
12212	Sakura-shi	1.0307	1.0400	1.0588	1.0646	1.0774	1.0992	1.0889	1.0821	1.0705	1.0700	1.0616	1.0445	1.0287	1.0387
12322	Shisui-machi	1.0096	1.0181	0.9965	0.9936	0.9755	1.0490	1.0105	1.0265	1.0356	1.0262	1.0563	1.1212	1.0746	1.0373
12323	Yachimata-machi	1.0061	0.9992	1.0053	0.9959	0.9544	1.0274	1.0048	1.0065	1.0175	1.0261	1.0261	1.0226	1.0190	1.0273

Table 10 (Continued)

1977-78	1978-79	1979-80	1980-81	1981-82	1982-83	1983-84	1984-85	1985-86	1986-87	1987-88	1988-89	1989-90	1990-91	1991-92
0.9931	0.9944	0.9951	0.9967	0.9983	1.0015	1.0024	1.0030	1.0026	0.9991	0.9935	0.9930	0.9935	0.9951	0.9962
0.9707	0.9685	0.9716	0.9885	0.9892	0.9848	0.9825	0.9895	0.9700	0.9694	0.9574	0.9582	0.9694	0.9747	0.9566
0.9809	0.9871	0.9896	0.9936	0.9964	1.0038	0.9963	0.9961	0.9937	0.9939	0.9944	0.9897	0.9942	0.9947	0.9925
0.9760	0.9787	0.9824	0.9848	0.9890	0.9874	0.9939	0.9936	0.9909	0.9854	0.9818	0.9827	0.9871	0.9868	0.9887
1.0080	1.0009	1.0111	1.0132	1.0266	1.0165	1.0097	1.0098	1.0010	1.0057	0.9990	0.9928	1.9916	0.9890	0.9958
1.0064	1.0077	1.0126	1.0063	1.0010	1.0037	1.0124	1.0146	1.0154	1.0227	1.0148	1.0176	1.0152	1.0159	1.0140
1.9915	0.9913	0.9900	0.9918	1.9986	0.9975	1.0012	1.0027	0.9994	1.0038	1.0056	1.0065	1.0034	1.0019	1.0038
1.0338	1.0211	1.0203	1.0282	1.0220	1.0188	1.0179	1.0177	1.0213	1.0193	1.0183	1.0159	1.0096	1.0121	1.0126
1.0349	1.0318	1.0260	1.0166	1.0143	1.0135	1.0118	1.0058	1.0090	1.0114	1.0149	1.0121	1.0061	1.0004	1.0047
1.0049	1.0034	1.0141	1.0376	1.0306	1.0150	1.0084	1.0053	1.0160	1.0243	1.0328	1.0194	1.0146	1.0100	1.0054
1.0265	1.0260	1.0193	1.0154	1.0077	1.0110	1.0137	1.0121	1.0100	1.0103	1.0098	1.0106	1.0079	1.0067	1.0052
1.1093	1.1036	1.0528	1.0379	1.0277	1.0220	1.0290	1.0080	1.0153	1.0138	1.0202	1.0174	1.0138	1.0133	1.0166
1.0562	1.0456	1.0467	1.0468	1.0445	1.0426	1.0301	1.0298	1.0232	1.0304	1.0417	1.0462	1.0337	1.0296	1.0266
1.0580	1.1030	1.1496	1.0888	1.1587	1.0546	1.0431	1.0148	1.0124	1.0227	1.0193	1.0424	0.0166	1.0142	1.0082
1.0236	1.0192	1.0201	1.0264	1.0343	1.0404	1.0310	1.0316	1.0315	1.0436	1.0630	1.0630	1.0685	1.0571	1.0617

Mathematical Characteristics of ROXY Index (II) - Periods of Intra-metropolitan Spatial-cycle Paths and Theoretically-ideal Formulations of ROXY Index (Hiroaka, Kawashima)

Table 11 Values of ROXY Index for Aggregated Case

Region	1963-64	1964-65	1965-66	1966-67	1967-68	1968-69	1969-70	1970-71	1971-72	1972-73	1973-74	1974-75	1975-76	1976-77
Chuo-line region	20.964	-10.817	-5.778	6.643	3.400	-2.619	-9.296	-23.532	-23.552	-23.807	-32.809	-33.170	-23.433	-26.309
Takasaki-line region	21.588	26.939	-0.442	-17.180	-36.846	-42.630	-40.052	-45.688	-60.787	-38.197	-42.632	-36.867	-31.266	-45.996
Joban-line region	109.807	85.232	59.888	40.455	21.307	31.772	-3.167	-14.555	-12.624	-32.517	-52.390	-36.153	-47.823	-40.552
Tokaido-line region	-45.261	-249.222	-161.971	-78.992	-85.289	-100.436	-55.276	-73.977	-77.671	-83.852	-81.768	-85.542	-60.543	-59.570
Sobu-line region	71.134	58.218	47.020	33.850	134.889	-65.063	-6.640	-15.205	-27.297	-45.560	-61.418	-92.778	-67.267	-68.142

1977-78	1978-79	1979-80	1980-81	1981-82	1982-83	1983-84	1984-85	1985-86	1986-87	1987-88	1988-89	1989-90	1990-91	1991-92
-22.485	-25.986	-26.428	-52.197	-29.206	-15.636	3.673	-7.574	-2.612	-10.953	-19.930	-23.752	-22.220	-20.511	-17.226
-48.283	-46.406	-48.735	-51.850	-56.355	-13.313	-22.510	-14.301	-19.562	-10.525	-17.936	-27.105	-25.530	-21.084	-15.315
-64.059	-86.646	109.106	-73.565	-87.879	-54.280	-35.751	-20.136	-20.467	-42.310	-19.146	-67.544	-46.872	-48.076	-40.521
-75.892	-46.713	-48.744	-46.753	-32.500	-18.719	-11.700	-4.322	-6.993	-19.004	-24.643	-19.321	-24.662	-7.732	-18.446
-79.424	104.809	121.506	-77.740	127.156	-69.835	-54.077	-34.256	-25.497	-45.548	-67.271	-89.451	-78.197	-66.556	-63.801

Table 12 Values of ROXY Index for Disaggregated Case

Region	1963-64	1964-65	1965-66	1966-67	1967-68	1968-69	1969-70	1970-71	1971-72	1972-73	1973-74	1974-75	1975-76	1976-77
Chuo-line region	-86.368	116.676	-98.234	-60.302	-84.684	-50.353	-70.276	-84.507	-77.507	-74.895	-79.059	-64.864	-59.608	-62.280
Takasaki-line region	-39.775	-53.111	-63.327	-83.770	-103.938	-115.689	-115.286	-106.326	-124.230	-95.775	-88.276	-81.683	-64.887	-82.276
Joban-line region	23.171	-23.249	-16.413	-42.689	-67.288	-69.385	-138.879	-144.316	-116.177	-137.244	-158.555	-131.975	-130.904	-118.733
Tokaido-line region	-147.400	-311.852	-178.547	-129.940	-124.237	-134.183	-110.218	-113.735	-112.984	-116.882	-142.835	-116.470	-89.981	-97.635
Sobu-line region	-61.545	-80.749	-50.812	-67.061	-51.833	-151.903	-136.131	-111.610	-125.829	-150.229	-170.580	-174.913	-143.096	-137.575

1977-78	1978-79	1979-80	1980-81	1981-82	1982-83	1983-84	1984-85	1985-86	1986-87	1987-88	1988-89	1989-90	1990-91	1991-92
-59.263	-54.140	-45.666	-55.779	-43.186	-29.062	-27.187	-16.861	-39.872	-46.582	-60.155	-65.230	-61.447	-54.339	-54.877
-81.089	-77.898	-79.058	-81.465	-81.436	-36.790	-36.411	-33.048	-41.238	-38.477	-47.060	-54.391	-49.563	-42.224	-38.020
-143.077	-144.941	-166.250	-112.814	-126.974	-95.646	-63.450	-50.070	-50.493	-53.641	-65.794	-88.406	-63.362	-60.941	-54.590
-90.832	-73.918	-54.981	-44.086	-41.981	-36.141	-39.685	-24.115	-48.472	-63.461	-80.629	-64.331	-60.977	-51.107	-60.598
-141.103	-157.602	-157.618	-113.011	-142.011	-89.198	-74.665	-47.519	-56.663	-74.777	-104.365	-120.839	-96.391	-83.625	-87.951

From these two tables, we obtain Panel (a) in Figure 1 showing values of the ROXY index for five railway-line regions in the aggregated case, and Panel (a) in Figure 2 showing values in the disaggregated case⁹. We can also obtain Panel (a) in Figures 3 through 12 showing the relationship of the ROXY index with the marginal change of its value for each railway-line region.

As can generally be seen from these twelve panels, values of ROXY index changes rather too much unsmoothly. Therefore, we have calculated both three-year-averaged (*i.e.*, three-year moving-average of) ROXY index and five-year-averaged (*i.e.*, five-year moving-average of) ROXY index in order to make the changes smoother. In our calculation, three-year-averaged ROXY index, $R_3(t)$, and five-year-averaged ROXY index, $R_5(t)$ are respectively defined as follows:

$$R_3(t) = (R(t-1) + R(t) + R(t+1)) / 3$$

and

$$R_5(t) = (R(t-2) + R(t-1) + R(t) + R(t+1) + R(t+2)) / 5,$$

where $R(t)$ is the value of the ordinary ROXY index for year t .

For the edges of time-series data, to which the above definition cannot apply, we set special formulas as follows:

(1-a) At the beginning-point of the three-year-averaged ROXY index

$$R_3(t) = (R(t) + 2 \times R(t+1)) / 3$$

(1-b) At the end-point of the three-year-averaged ROXY index

$$R_3(t) = (2 \times R(t-1) + R(t)) / 3$$

(2-a) At the beginning-point of the five-year-averaged ROXY index

$$R_5(t) = (3 \times R(t) + R(t+1) + R(t+2)) / 5$$

$$R_5(t) = (2 \times R(t-1) + R(t) + R(t+1) + R(t+2)) / 5$$

(2-b) At the end-point of the five-year-averaged ROXY index

$$R_5(t) = (R(t-2) + R(t-1) + 3 \times R(t)) / 5$$

$$R_5(t) = (R(t-2) + R(t-1) + R(t) + 2 \times R(t+1)) / 5$$

Table 13 shows the values of the three-year-averaged ROXY index for the aggregated case and Table 14 for the disaggregated case, while Table 15 shows the values of the five-year-averaged ROXY index for the aggregated case and Table 16 for the disaggregated case.

From Tables 13 through 16, we obtain Panels (b) and (c) in Figure 1 respectively showing values of the three- and five-year-averaged ROXY indices for the five railway-line regions in the aggregated case, and Panels (b) and (c) in Figure 2 respectively showing

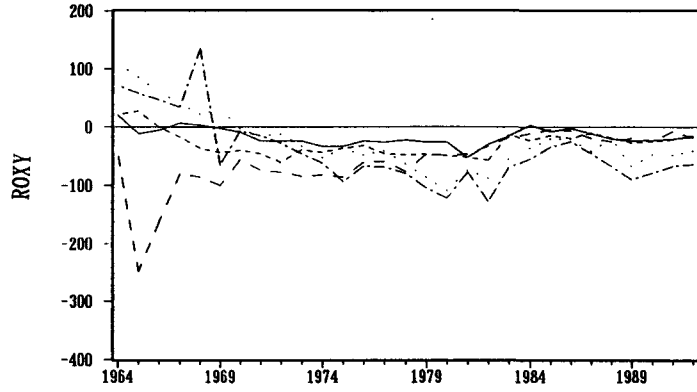

(a) ROXY index by annual population data (1963-92)

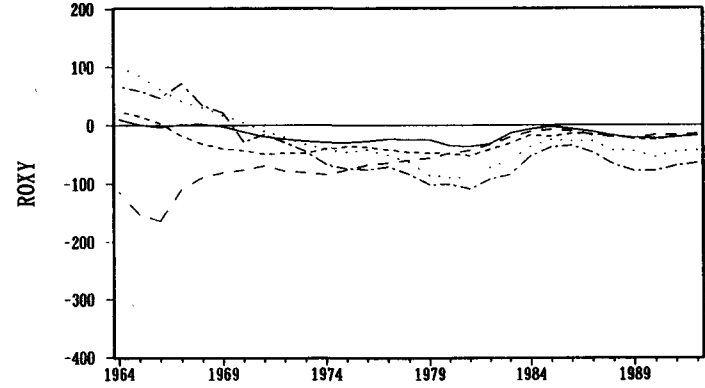

(b) Three-year moving-average of ROXY index (1963-92)

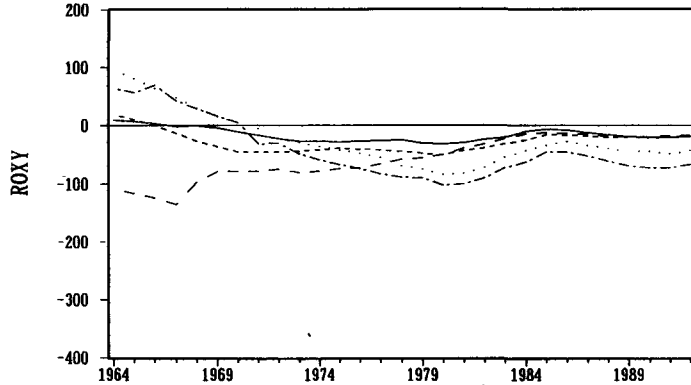

(c) Five-year moving-average of ROXY index (1963-92)

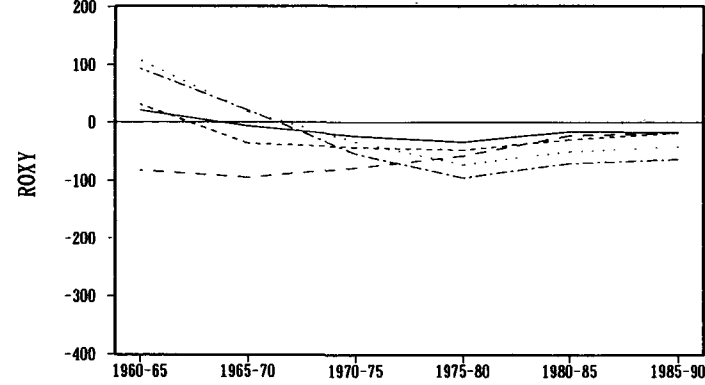

(d) ROXY index by National Population Census data (1960-90)

Chuo-line:———— Takasaki-line:..... Joban-line: - - - - Tokaido-line: - · - · - Sobu-line: - - - - -

Figure 1 Four Types of ROXY Indices for Five Railway-line Regions: Aggregated Case

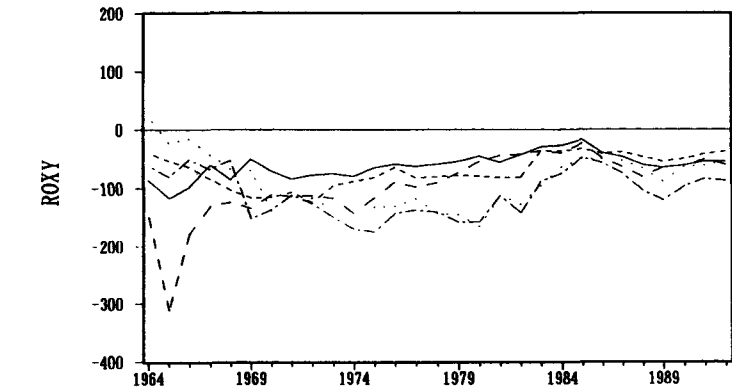

(a) ROXY index by annual population data (1963-92)

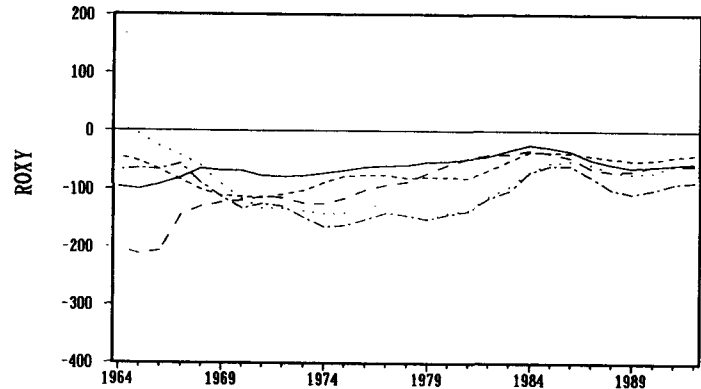

(b) Three-year moving-average of ROXY index (1963-92)

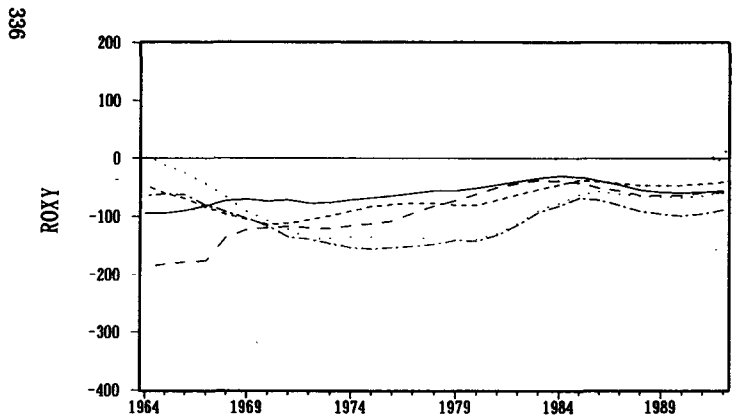

(c) Five-year moving-average of ROXY index (1963-92)

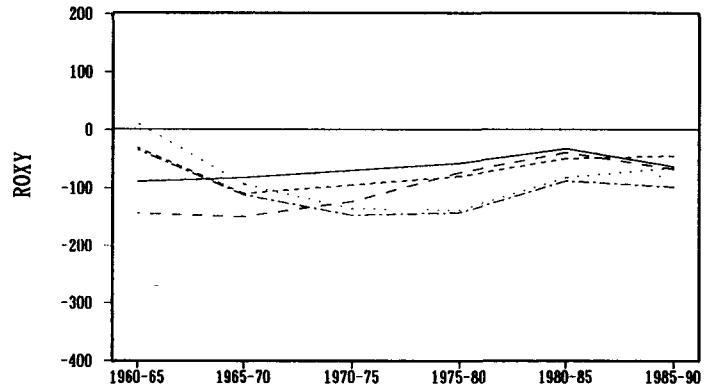

(d) ROXY index by National Population Census data (1960-90)

Chuo-line:—— Takasaki-line:..... Joban-line:----- Tokaido-line:-- -- Sobu-line:-----

Figure 2 Four Types of ROXY Indices for Five Railway-line Regions: Disaggregated Case

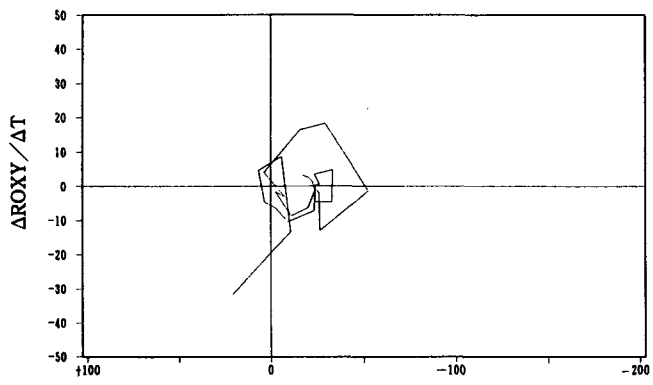

(a) ROXY index by annual population data (1963-92)

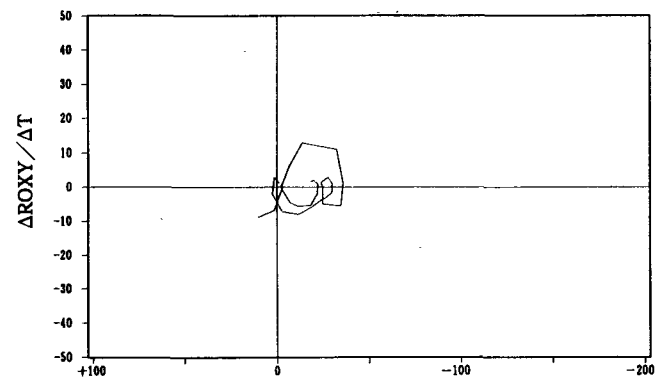

(b) Three-year moving-average of ROXY index (1963-92)

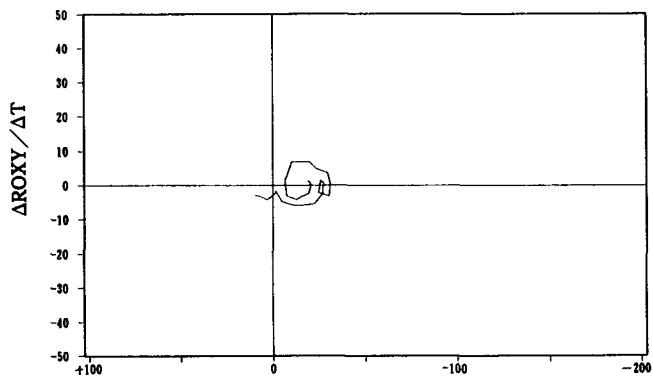

(c) Five-year moving-average of ROXY index (1963-92)

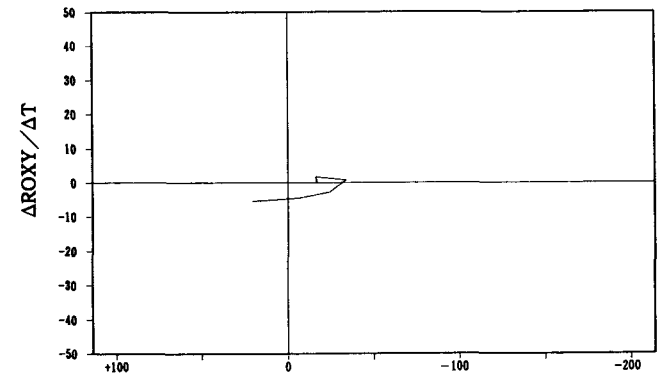

(d) ROXY index by National Population Census data (1960-90)

Figure 3 Four Types of ROXY Indices and Their Marginal Values for Chuo-line Region: Aggregated Case

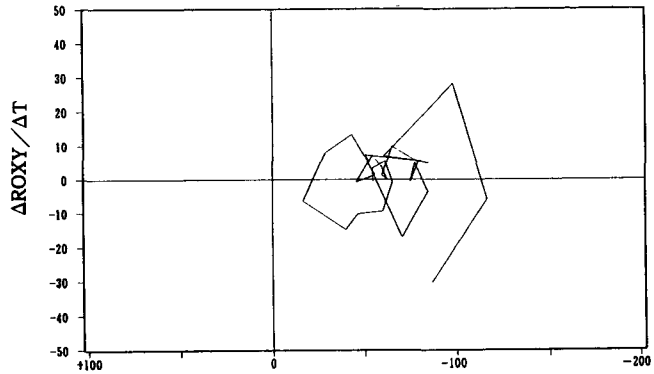

(a) ROXY index by annual population data (1963-92)

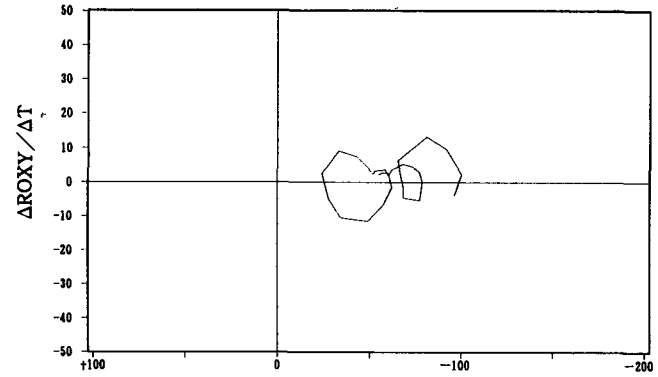

(b) Three-year moving-average of ROXY index (1963-92)

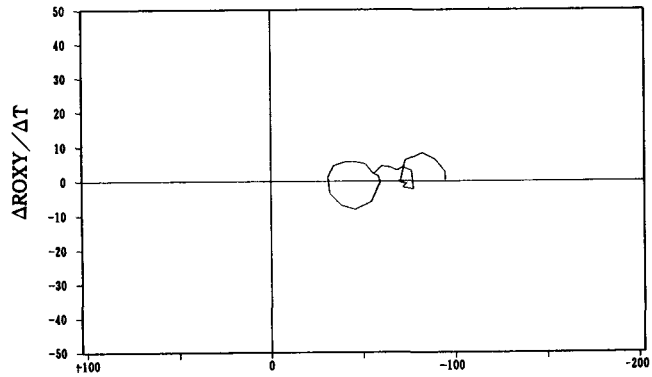

(c) Five-year moving-average of ROXY index (1963-92)

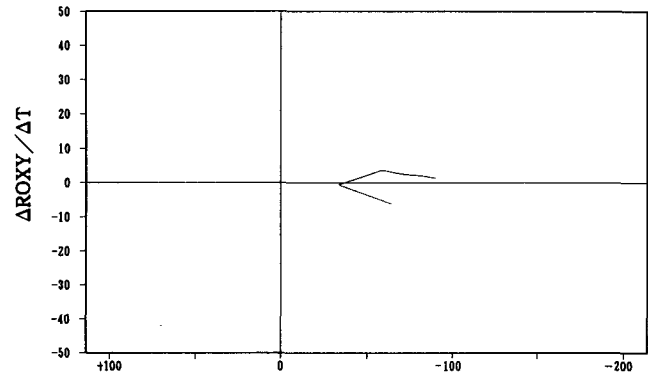

(d) ROXY index by National Population Census data (1960-90)

Figure 4 Four Types of ROXY Indices and Their Marginal Values for Chuo-line Region: Disaggregated Case

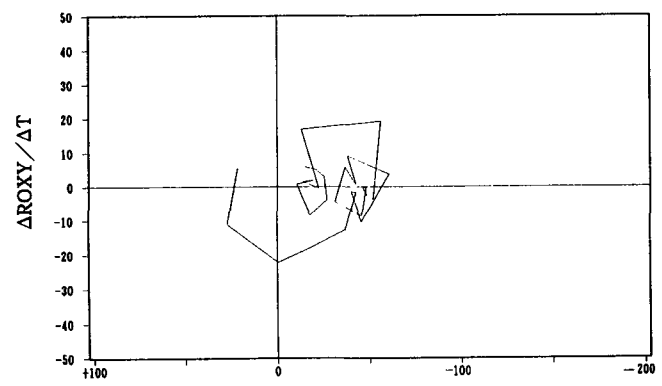

(a) ROXY index by annual population data (1963-92)

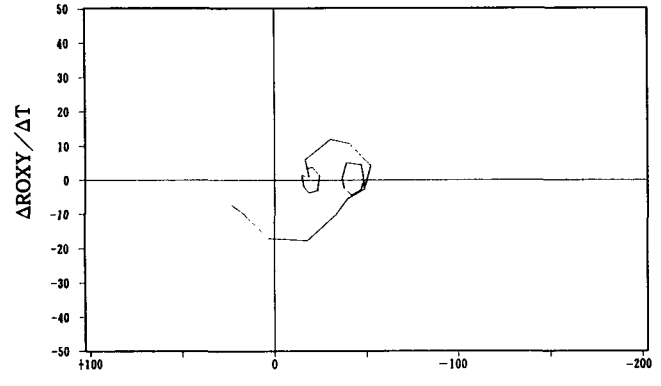

(b) Three-year moving-average of ROXY index (1963-92)

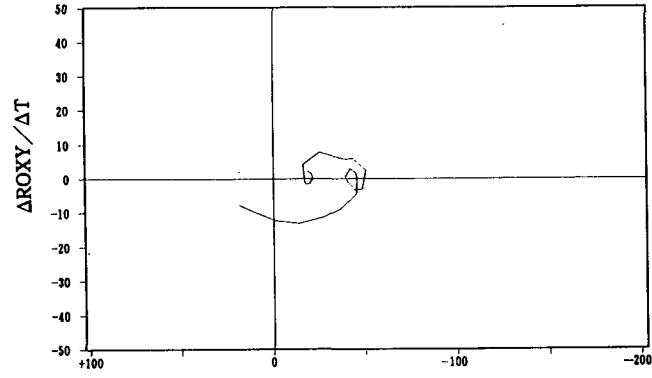

(c) Five-year moving-average of ROXY index (1963-92)

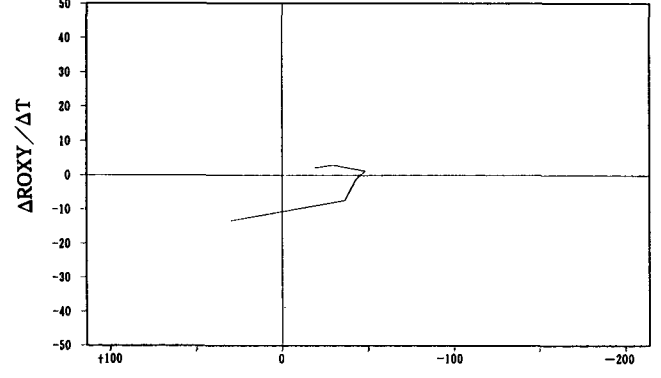

(d) ROXY index by National Population Census data (1960-90)

Figure 5 Four Types of ROXY Indices and Their Marginal Values for Takasaki-line Region: Aggregated Case

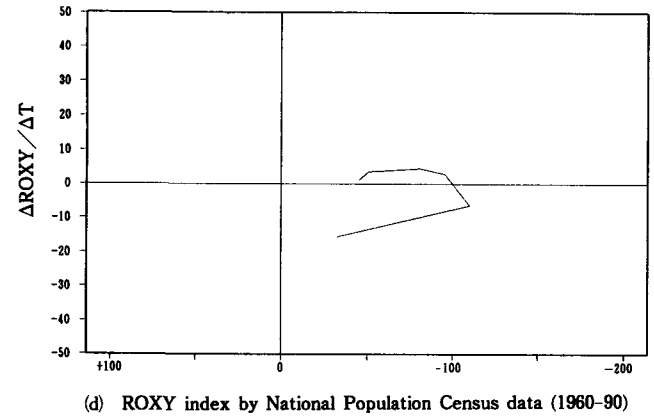
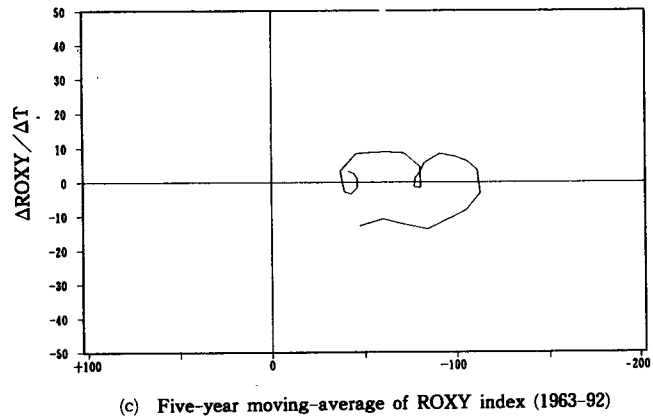
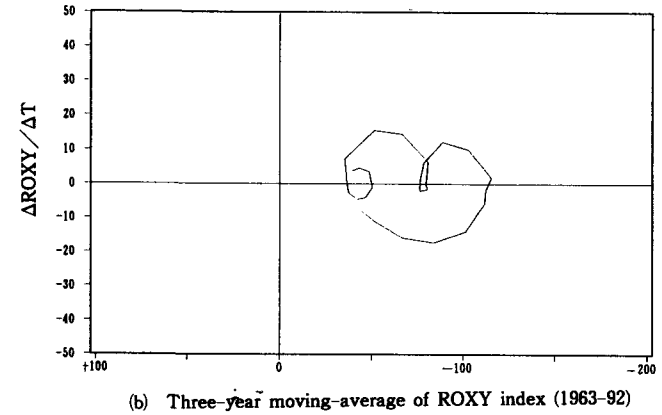
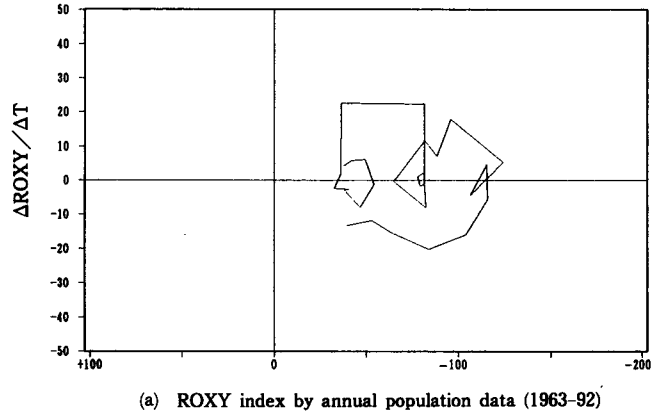
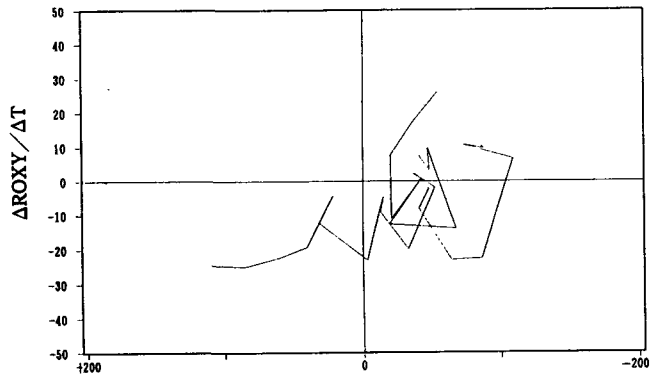
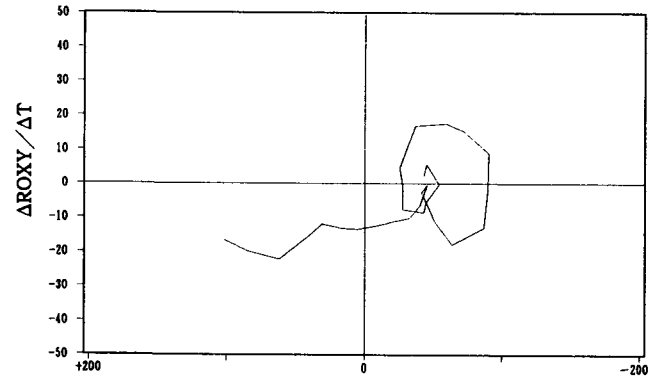

Figure 6 Four Types of ROXY Indices and Their Marginal Values for Takasaki-line Region: Disaggregated Case



(a) ROXY index by annual population data (1963-92)



(b) Three-year moving-average of ROXY index (1963-92)

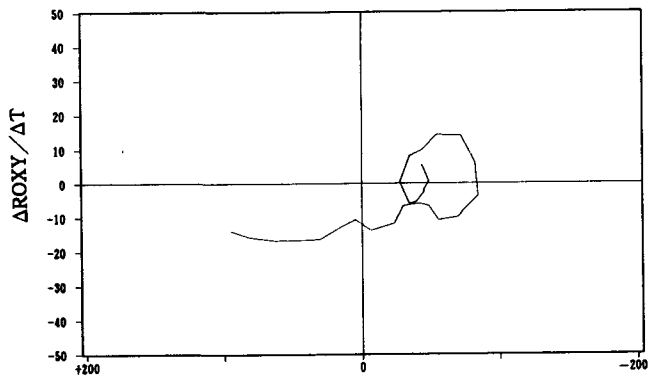

(c) Five-year moving-average of ROXY index (1963-92)

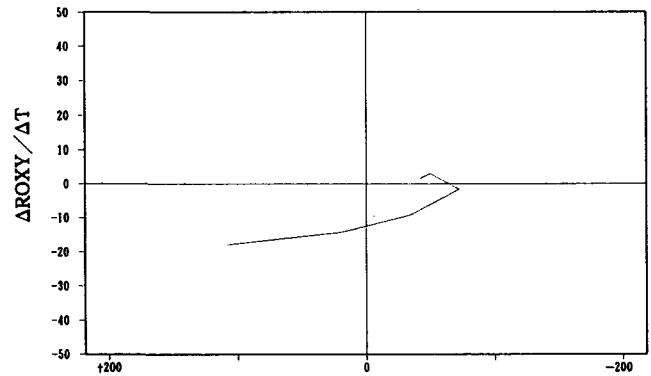

(d) ROXY index by National Population Census data (1960-90)

Figure 7 Four Types of ROXY Indices and Their Marginal Values for Joban-line Region: Aggregated Case

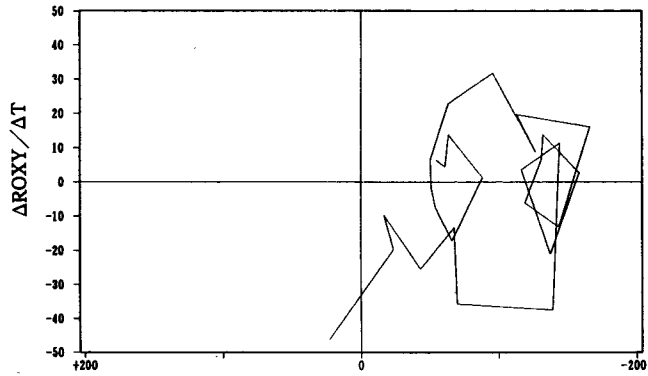

(a) ROXY index by annual population data (1963-92)

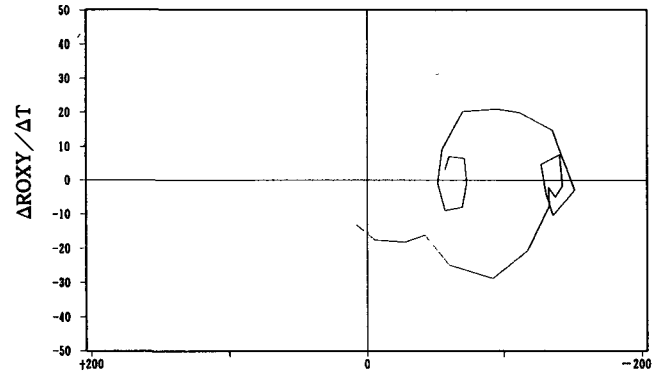

(b) Three-year moving-average of ROXY index (1963-92)

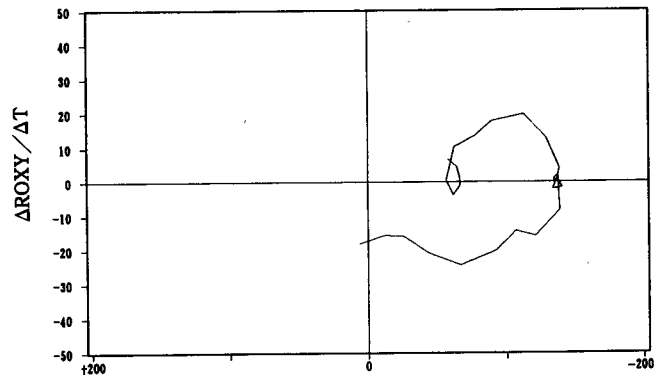

(c) Five-year moving-average of ROXY index (1963-92)

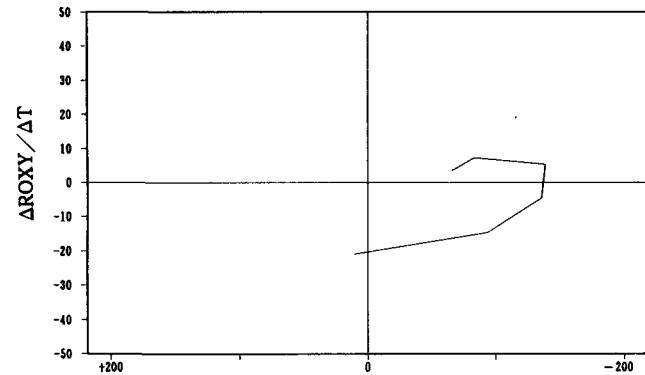

(d) ROXY index by National Population Census data (1960-90)

Figure 8 Four Types of ROXY Indices and Their Marginal Values for Joban-line Region: Disaggregated Case

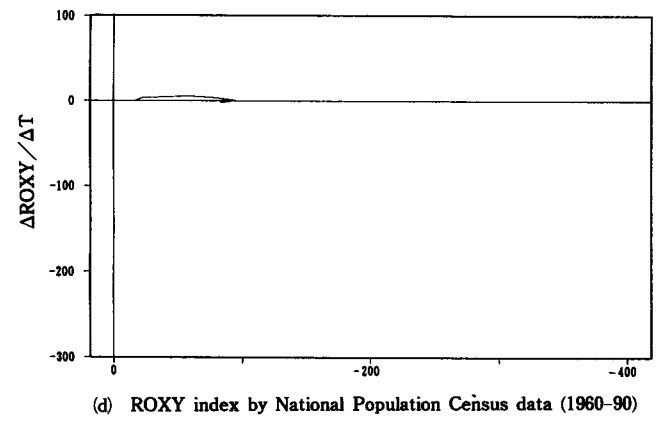
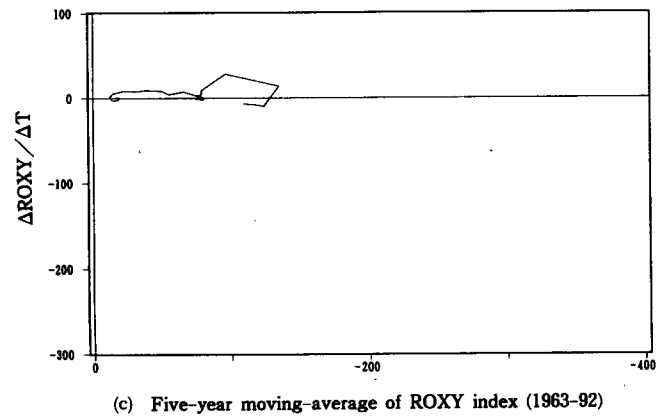
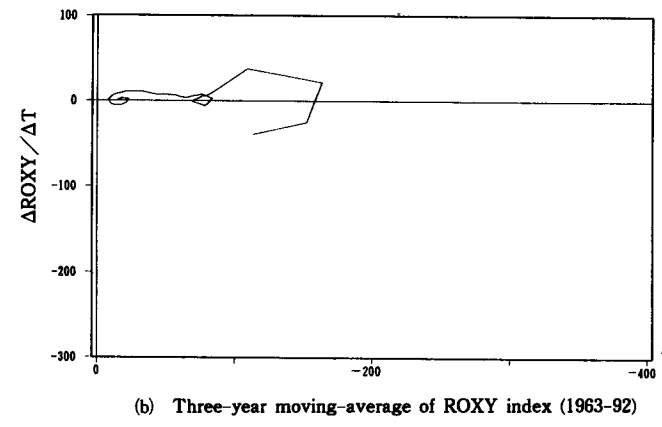
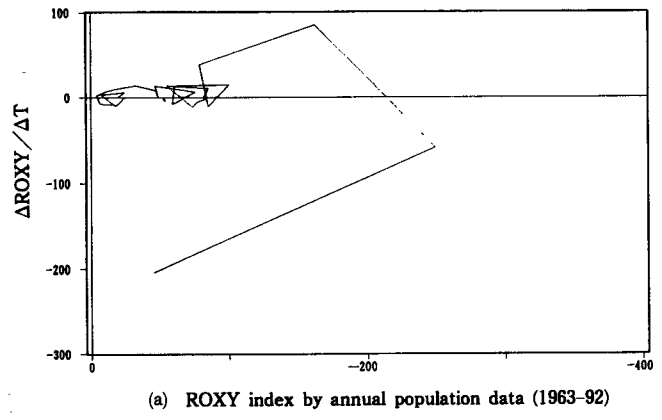
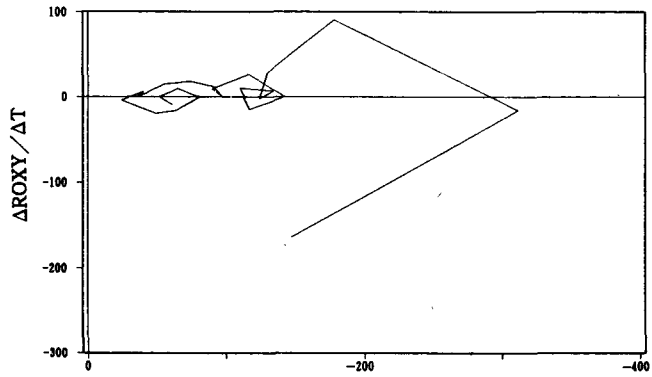
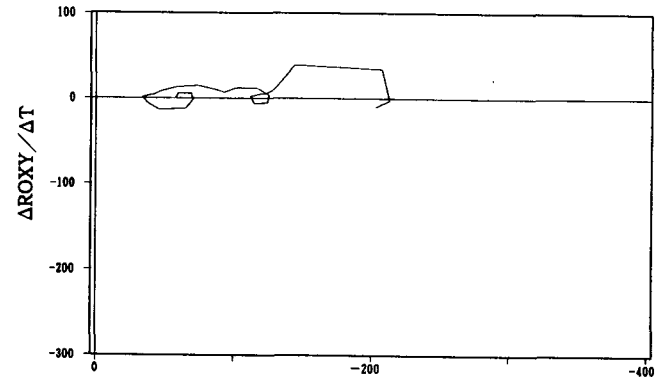

Figure 9 Four Types of ROXY Indices and Their Marginal Values for Tokaido-line Region: Aggregated Case



(a) ROXY index by annual population data (1963-92)



(b) Three-year moving-average of ROXY index (1963-92)

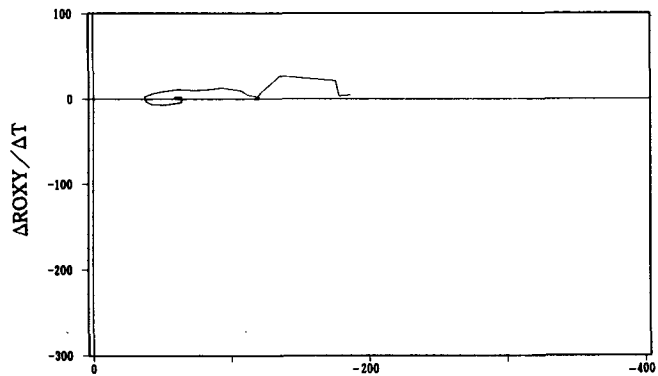

(c) Five-year moving-average of ROXY index (1963-92)

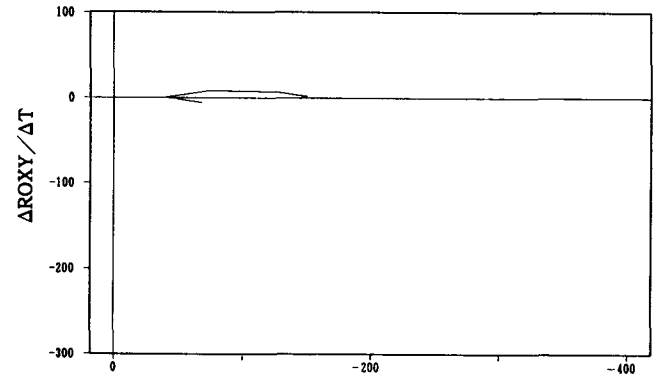

(d) ROXY index by National Population Census data (1960-90)

Figure 10 Four Types of ROXY Indices and Their Marginal Values for Tokaido-line Region: Disaggregated Case

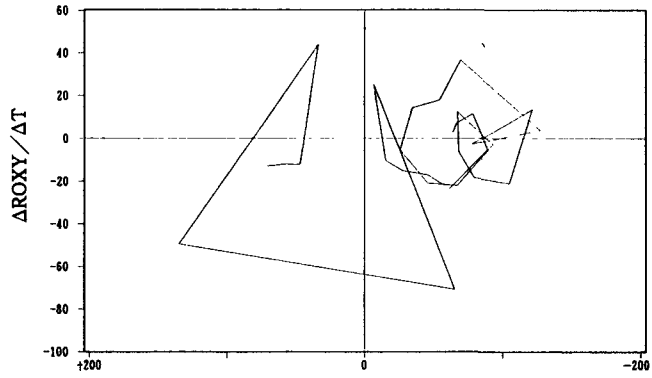

(a) ROXY index by annual population data (1963-92)

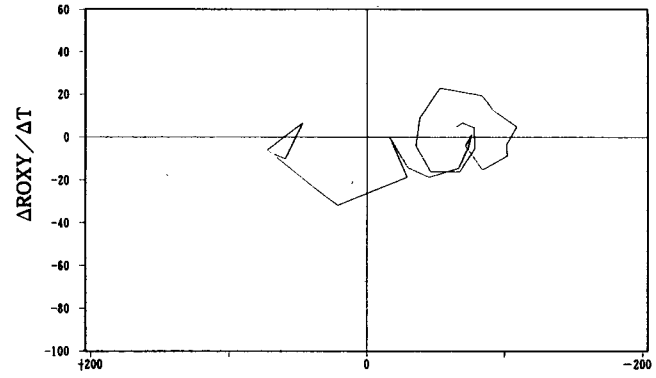

(b) Three-year moving-average of ROXY index (1963-92)

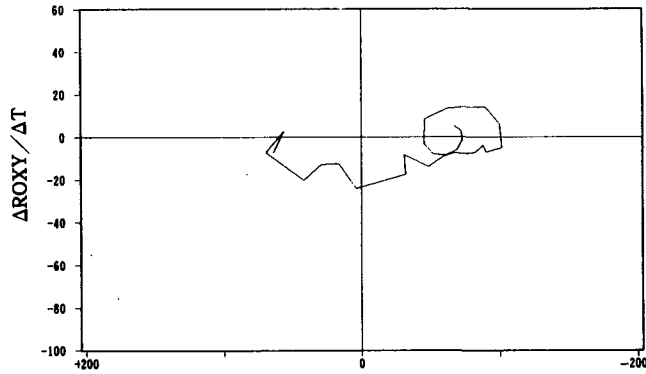

(c) Five-year moving-average of ROXY index (1963-92)

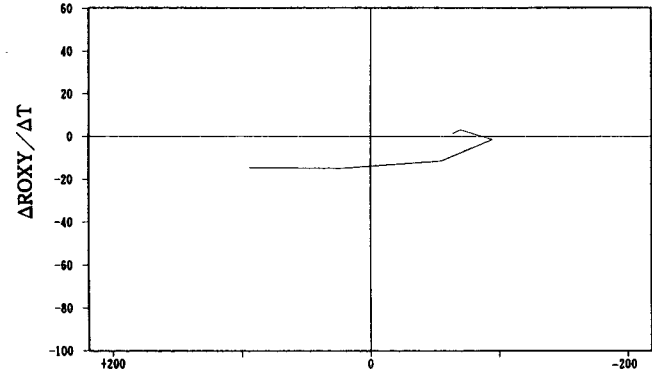

(d) ROXY index by National Population Census data (1960-90)

Figure 11 Four Types of ROXY Indices and Their Marginal Values for Sobu-line Region: Aggregated Case

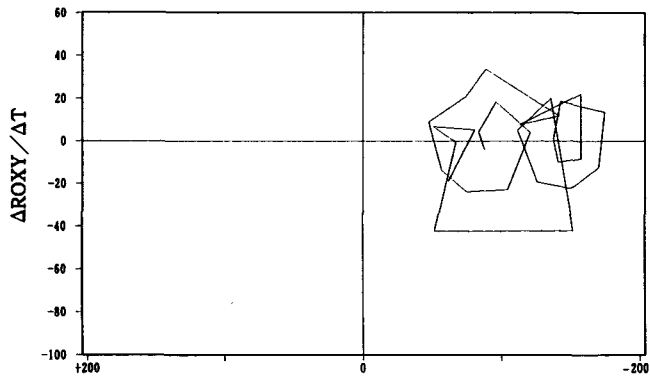

(a) ROXY index by annual population data (1963-92)

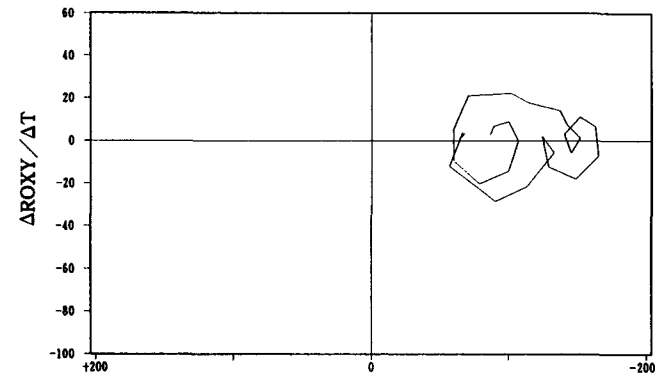

(b) Three-year moving-average of ROXY index (1963-92)

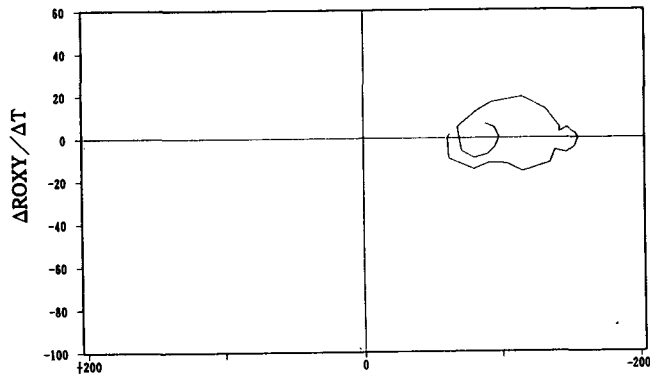

(c) Five-year moving-average of ROXY index (1963-92)

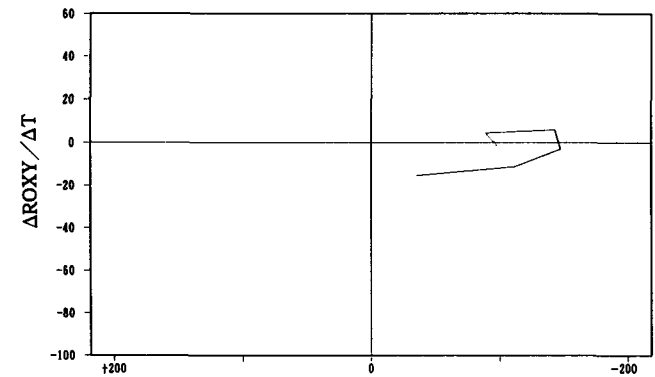

(d) ROXY index by National Population Census data (1960-90)

Figure 12 Four Types of ROXY Indices and Their Marginal Values for Sobu-line Region: Disaggregated Case

Table 13 Values of 3-year-averaged ROXY Index for Aggregated Case

Region	1963-64	1964-65	1965-66	1966-67	1967-68	1968-69	1969-70	1970-71	1971-72	1972-73	1973-74	1974-75	1975-76	1976-77
Chuo-line region	10.370	1.456	-3.317	1.422	2.474	-2.839	-11.816	-18.793	-23.630	-26.722	-29.929	-29.804	-27.637	-24.076
Takasaki-line region	23.371	16.028	3.106	-18.156	-32.219	-39.843	-42.790	-48.843	-48.224	-47.205	-39.232	-36.922	-38.043	-41.849
Joban-line region	101.615	84.976	61.858	40.550	31.178	16.638	4.683	-10.115	-19.899	-32.510	-40.353	-45.455	-41.509	-50.811
Tokaido-line region	-113.248	-152.151	-163.395	-108.751	-88.239	-80.333	-76.563	-68.974	-78.500	-81.097	-83.721	-75.951	-68.552	-65.335
Sobu-line region	66.829	58.791	46.362	71.919	34.558	21.062	-28.969	-16.380	-29.354	-44.758	-66.586	-73.821	-76.062	-71.611

1977-78	1978-79	1979-80	1980-81	1981-82	1982-83	1983-84	1984-85	1985-86	1986-87	1987-88	1988-89	1989-90	1990-91	1991-92
-24.927	-24.966	-34.870	-35.943	-32.346	-13.723	-6.512	-2.171	-7.046	-11.165	-18.212	-21.968	-22.161	-19.986	-18.321
-46.895	-47.808	-48.997	-52.313	-40.506	-30.726	-16.708	-18.791	-14.796	-16.008	-18.522	-23.524	-24.573	-20.643	-17.238
-63.752	-86.604	-89.773	-90.183	-71.908	-59.303	-36.722	-25.451	-27.638	-27.307	-43.000	-44.521	-54.164	-45.156	-43.040
-60.725	-57.116	-47.403	-42.666	-32.657	-20.973	-11.581	-7.672	-10.106	-16.880	-20.989	-22.875	-17.239	-16.947	-14.875
-84.125	-101.913	-101.352	-108.801	-91.577	-83.689	-52.723	-37.943	-35.100	-46.105	-67.423	-78.306	-78.068	-69.518	-64.720

Table 14 Values of 3-year-averaged ROXY Index for Disaggregated Case

Region	1963-64	1964-65	1965-66	1966-67	1967-68	1968-69	1969-70	1970-71	1971-72	1972-73	1973-74	1974-75	1975-76	1976-77
Chuo-line region	-96.471	-100.426	-91.737	-81.073	-65.113	-68.438	-68.379	-77.430	-78.969	-77.153	-72.939	-67.844	-62.251	-60.384
Takasaki-line region	-44.220	-52.071	-66.736	-83.678	-101.132	-111.638	-112.434	-115.281	-108.777	-102.760	-88.578	-78.282	-76.282	-76.084
Joban-line region	7.697	-5.497	-27.450	-42.130	-59.787	-91.851	-117.527	-133.124	-132.579	-137.325	-142.591	-140.478	-127.204	-130.905
Tokaido-line region	-202.217	-212.599	-206.780	-144.242	-129.454	-122.880	-119.379	-112.312	-114.534	-124.234	-125.396	-116.429	-101.362	-92.816
Sobu-line region	-67.946	-64.369	-66.208	-56.569	-90.266	-113.289	-133.215	-124.523	-129.223	-148.879	-165.241	-162.863	-151.861	-140.591

1977-78	1978-79	1979-80	1980-81	1981-82	1982-83	1983-84	1984-85	1985-86	1986-87	1987-88	1988-89	1989-90	1990-91	1991-92
-58.561	-53.023	-51.862	-48.210	-42.676	-33.145	-24.370	-27.974	-34.438	-48.870	-57.322	-62.277	-60.339	-56.888	-54.698
-80.421	-79.349	-79.474	-80.653	-66.564	-51.546	-35.416	-36.899	-37.588	-42.258	-46.643	-50.338	-48.726	-43.269	-39.421
-135.584	-151.423	-141.335	-135.346	-111.811	-95.356	-69.722	-54.671	-51.401	-56.642	-69.280	-72.521	-70.903	-59.631	-56.707
-87.462	-73.244	-57.662	-47.016	-40.736	-39.269	-33.314	-37.424	-45.349	-64.187	-69.474	-68.646	-58.805	-57.561	-57.434
-145.427	-152.108	-142.744	-137.547	-114.740	-101.958	-70.461	-59.616	-59.653	-78.602	-99.994	-107.198	-100.285	-89.322	-86.509

Table 15 Values of 5-year-averaged ROXY Index for Aggregated Case

Region	1963-64	1964-65	1965-66	1966-67	1967-68	1968-69	1969-70	1970-71	1971-72	1972-73	1973-74	1974-75	1975-76	1976-77
Chuo-line region	9.259	6.395	2.882	-1.834	-1.530	-5.081	-11.120	-16.561	-22.599	-27.374	-27.354	-27.906	-27.641	-26.277
Takasaki-line region	18.252	10.498	-1.188	-14.032	-27.430	-36.479	-45.201	-45.471	-45.471	-44.834	-41.950	-38.992	-41.009	-41.764
Joban-line region	94.908	81.038	63.338	47.731	30.051	15.163	4.547	-6.218	-23.051	-29.648	-36.301	-41.887	-48.195	-55.047
Tokaido-line region	-109.395	-116.141	-124.147	-135.182	-96.393	-78.794	-78.530	-78.242	-74.509	-80.562	-77.875	-74.255	-72.663	-65.652
Sobu-line region	63.728	56.271	69.022	41.783	28.811	16.366	4.137	-31.953	-31.224	-48.452	-58.864	-67.033	-73.806	-82.484

1977-78	1978-79	1979-80	1980-81	1981-82	1982-83	1983-84	1984-85	1985-86	1986-87	1987-88	1988-89	1989-90	1990-91	1991-92
-24.928	-30.681	-31.260	-29.890	-23.959	-20.188	-10.271	-6.620	-7.479	-12.964	-15.894	-19.473	-20.728	-20.187	-18.882
-44.137	-48.254	-50.326	-43.332	-38.553	-31.666	-25.208	-16.042	-16.967	-17.886	-20.132	-20.436	-21.394	-20.870	-18.512
-69.637	-74.786	-84.251	-82.295	-72.116	-54.322	-43.703	-34.589	-27.562	-33.921	-39.268	-44.790	-44.432	-48.707	-43.302
-58.292	-55.534	-50.120	-38.686	-31.683	-22.799	-14.847	-12.148	-13.332	-14.857	-18.925	-19.072	-18.961	-17.722	-17.547
-88.230	-90.324	-102.127	-100.209	-90.063	-72.613	-62.164	-45.843	-45.330	-52.405	-61.193	-69.405	-73.055	-72.361	-67.231

Table 16 Values of 5-year-averaged ROXY Index for Disaggregated Case

Region	1963-64	1964-65	1965-66	1966-67	1967-68	1968-69	1969-70	1970-71	1971-72	1972-73	1973-74	1974-75	1975-76	1976-77
Chuo-line region	-94.803	-94.466	-89.253	-82.050	-72.770	-70.025	-73.465	-71.508	-77.249	-76.166	-71.187	-68.141	-65.015	-60.031
Takasaki-line region	-47.153	-59.985	-68.784	-83.967	-96.402	-105.002	-113.094	-111.461	-105.979	-99.258	-90.970	-82.579	-79.642	-77.567
Joban-line region	5.970	-12.122	-25.294	-43.805	-66.931	-92.511	-107.209	-121.200	-139.034	-137.653	-134.971	-135.482	-136.649	-133.926
Tokaido-line region	-186.520	-181.887	-178.395	-175.752	-135.425	-122.463	-119.072	-117.600	-119.331	-120.581	-115.830	-112.761	-107.551	-93.767
Sobu-line region	-63.239	-61.297	-62.400	-80.472	-91.548	-103.707	-115.461	-135.140	-138.876	-146.632	-152.929	-155.279	-153.453	-150.858

1977-78	1978-79	1979-80	1980-81	1981-82	1982-83	1983-84	1984-85	1985-86	1986-87	1987-88	1988-89	1989-90	1990-91	1991-92
-56.191	-55.426	-51.607	-45.567	-40.176	-34.415	-31.234	-31.913	-38.131	-45.740	-54.657	-57.550	-59.210	-58.154	-56.084
-77.042	-80.357	-80.189	-71.329	-63.032	-53.830	-45.784	-37.193	-39.247	-42.843	-46.146	-46.343	-46.252	-44.444	-41.169
-140.781	137.163	138.811	-129.325	-113.027	-89.791	-77.327	-62.660	-56.689	-61.681	-64.339	-66.429	-66.619	-64.378	-57.615
-81.470	-72.291	-61.160	-50.222	-43.375	-37.202	-38.079	-42.375	-51.273	-56.202	-63.574	-64.101	-63.529	-59.522	-58.775
-147.399	-141.382	-142.269	-131.888	-115.301	-93.281	-82.011	-68.564	-71.598	-80.833	-90.607	-95.999	-98.634	-95.351	-88.774

values of the three- and five-year-averaged ROXY indices for the five railway-line regions in the disaggregated case. We can also obtain Panels (b) and (c) in Figures 3 through 12 showing the three- and five-year-averaged ROXY indices and marginal changes of their values for each railway-line region⁴⁾. For the purpose of comparison, we have Panel (d) in Figures 1 through 12 showing the corresponding graphs depicted based on the every fifth year data of the National Population Census.

As can be generally seen from these panels, changes in values of the ROXY index calculated by use of the annual data have more minute features than those by use of the National Census data, (*i.e.*, five-year data). Figure 13 shows schematic interpretation of the possible spatial-cycle paths connoted by changes in the value of the ROXY index calculated by use of the annual population data. The ROXY index would change rather monotonically in the stage of accelerating decentralization (*i.e.*, AD stage), while it would generate the paths of sub-cycles in the stage of decelerating decentralization (*i.e.*, DD stage) with the period of sub-cycles.

In Table 17 are shown the time of transition from the AD stage to the DD stage, and the value of the ROXY index at the transition time. From this table, it can be seen that the Chuo-line region entered the DD stage in 1965. One year later, in 1966, the Tokaido-line region entered the DD stage. The Takasaki-line region entered the DD stage in 1971, and the Joban-line and Sobu-line regions, in 1975.

Table 18 shows the value of the normalized three-year-averaged ROXY index, which is defined as the value of the three-year-averaged ROXY index divided by the value observed at the time of transition from AD stage to the DD stage. Figure 14 which we construct based on Table 18, would tell us that approximately before the middle of the 1970's the five railway-line regions were on the different spatial-cycle stages but that after around 1980 they became to tend to move almost in parallel with each other along the path of spatial-cycles. In conjunction with this, it should also be noticed that Figure 14 would suggest that there would exist sub-cycles with the period of approximately ten years in the DD stage for the five railway-line regions.

It would now be appropriate for us to clarify the image of the spatial sub-cycles that are observed in the ROXY-ΔROXY plane for the DD stage by showing which trajectory the sub-cycle corresponds (i) on the growth-ratio plane and (ii) on the growth-rate plane. To make our discussion easier, let us introduce the concept of the iso-ROXY line, along which the value of ROXY index is constant.

First, let us derive the iso-ROXY line on the growth-ratio plane. The value of the ROXY index has its relation to the growth ratio as follows:

$$R_0 = \left(\frac{\left(\frac{S_x \cdot X + S_y \cdot Y}{S_x + S_y} \right)}{\frac{(X + Y)}{2}} - 1 \right) \times 10^4 \quad (1.1)$$

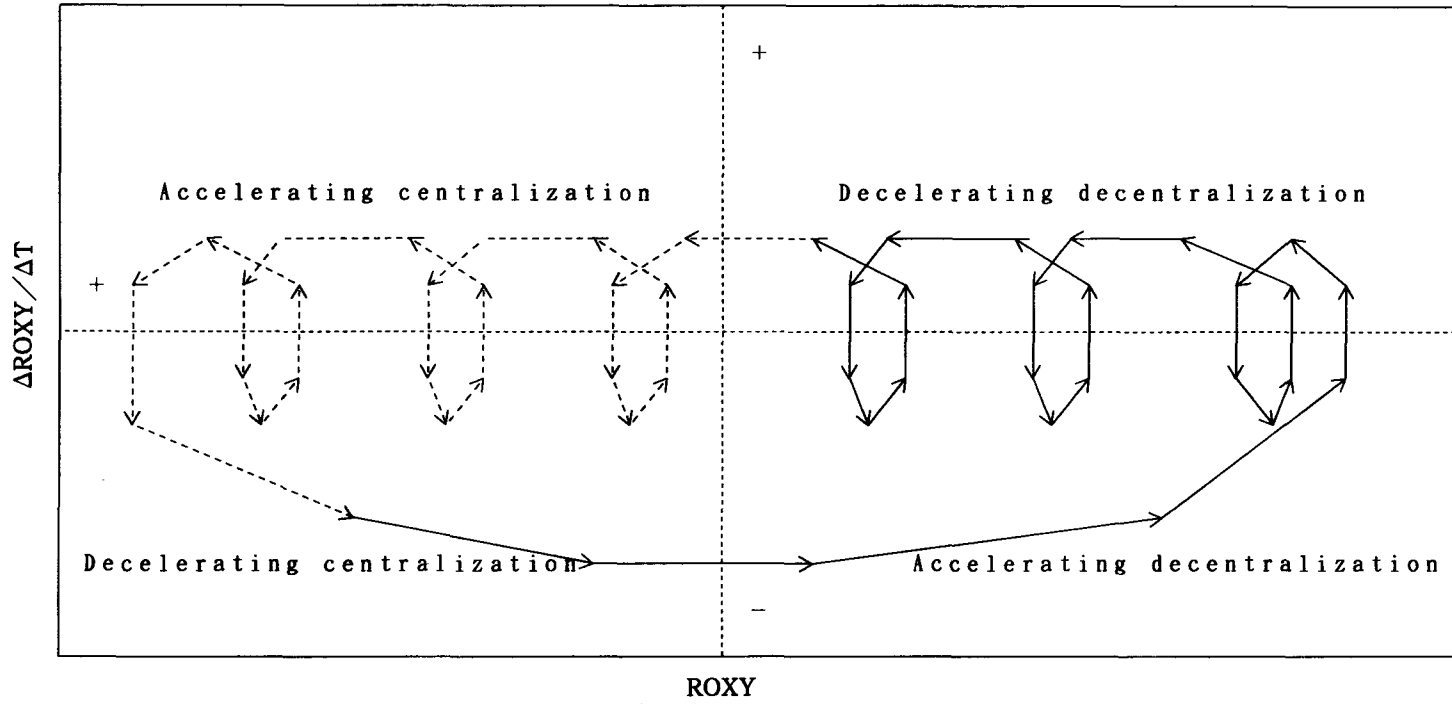

Figure 13 Possible Urban Spatial-cycle Paths Presented by Changes in Value of ROXY Index

Table 17 Time of Transition from Accelerating Decentralization to Decelerating Decentralization

Regions	Transition time	Value of ROXY index at the transition time
Chuo-line region	1964 to 1965	-98.4
Takasaki-line region	1970 to 1971	-112.0
Joban-line region	1974 to 1975	-141.5
Tokaido-line region	1965 to 1966	-209.6
Sobu-line region	1974 to 1975	-164.0

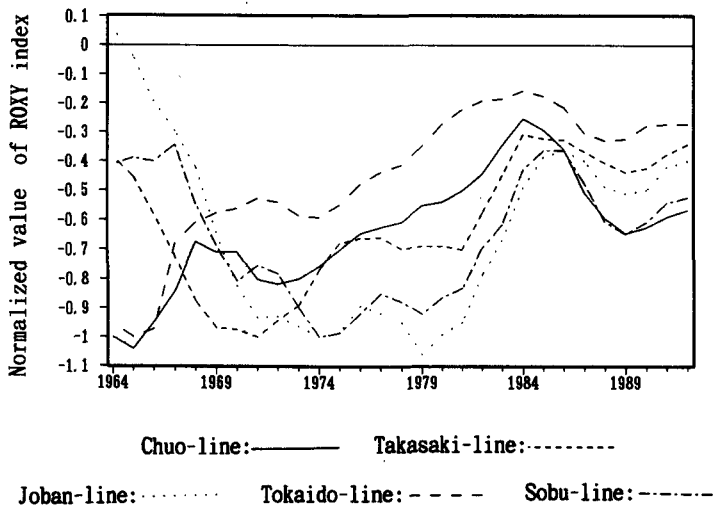

Figure 14 Normalization of Values of Three-year Moving-average of ROXY Index for Five Railway-line Regions (1963-1992) : Aggregated Case

Table 18 Values of Normalized 3-year-averaged ROXY Index for Disaggregated Case

Region	1963-64	1964-65	1965-66	1966-67	1967-68	1968-69	1969-70	1970-71	1971-72	1972-73	1973-74	1974-75	1975-76	1976-77
Chuo-line region	-1.000	-1.041	-0.951	-0.840	-0.675	-0.709	-0.709	-0.803	-0.819	-0.800	-0.756	-0.703	-0.645	-0.626
Takasaki-line region	-0.384	-0.452	-0.579	-0.726	-0.877	-0.968	-0.975	-1.000	-0.944	-0.891	-0.768	-0.679	-0.662	-0.660
Joban-line region	0.054	-0.039	-0.193	-0.295	-0.419	-0.644	-0.824	-0.934	-0.930	-0.963	-1.000	-0.985	-0.892	-0.918
Tokaido-line region	-0.951	-1.000	-0.973	-0.678	-0.609	-0.578	-0.562	-0.528	-0.539	-0.584	-0.590	-0.548	-0.477	-0.437
Sobu-line region	-0.411	-0.390	-0.401	-0.342	-0.546	-0.686	-0.806	-0.754	-0.782	-0.901	-1.000	-0.986	-0.919	-0.851

1977-78	1978-79	1979-80	1980-81	1981-82	1982-83	1983-84	1984-85	1985-86	1986-87	1987-88	1988-89	1989-90	1990-91	1991-92
-0.607	-0.550	-0.538	-0.500	-0.442	-0.344	-0.253	-0.290	-0.357	-0.507	-0.594	-0.646	-0.625	-0.590	-0.567
-0.698	-0.688	-0.689	-0.700	-0.577	-0.447	-0.307	-0.320	-0.326	-0.367	-0.405	-0.437	-0.423	-0.375	-0.342
-0.951	-1.062	-0.991	-0.949	-0.784	-0.669	-0.489	-0.383	-0.360	-0.397	-0.486	-0.509	-0.497	-0.418	-0.398
-0.411	-0.345	-0.271	-0.221	-0.192	-0.185	-0.157	-0.176	-0.213	-0.302	-0.327	-0.323	-0.277	-0.271	-0.270
-0.880	-0.921	-0.864	-0.832	-0.694	-0.617	-0.426	-0.361	-0.361	-0.476	-0.605	-0.649	-0.607	-0.541	-0.524

where R_0 : Value of ROXY index

X : Annual growth ratio of population in the center of a metropolitan area

Y : Annual growth ratio of population in the suburbs of the metropolitan area

S_x : Average of reversed distances of localities each of which belongs to the center of the metropolitan area

S_y : Average of reversed distances of localities each of which belongs to the suburbs of the metropolitan area.

From equation (1.1), the relation of X with Y under the condition that the value of the ROXY index is constant can be derived as follows:

$$Y = - \frac{R_0 \times 10^{-4} + \frac{S_y - S_x}{S_x + S_y}}{R_0 \times 10^{-4} + \frac{S_x - S_y}{S_x + S_y}} \cdot X \quad (1.2)$$

Equation (1.2) shows that the iso-ROXY line on the growth ratio plane is straight through the origin. Replacing R_0 by zero, the boundary between the stage of decelerating centralization (*i.e.*, DC stage) and the AD stage is shown as follows:

$$Y = X \quad (1.3)$$

Equation (1.3) expresses the 45 degree line on the growth ratio plane.

Since the reversed distance of localities in the center of a metropolitan area is greater than that of localities in the suburbs, it follows that $S_x > S_y$. Therefore we have:

$$\frac{S_y - S_x}{S_x + S_y} < 0 \quad \text{and} \quad \frac{S_x - S_y}{S_x + S_y} < 0. \quad (1.4)$$

In case when the value of the ROXY index is positive and when its value gradually increases, the absolute value of the numerator of the slant becomes smaller, and that of the denominator would become larger. Consequently, the slant becomes flatter. In case when the value of the ROXY index is negative, and when its absolute value gradually increases, the slant becomes steeper. As a result, the iso-ROXY lines on the growth ratio plane will be rendered as shown in Figure 15.

Secondly, let us derive the iso-ROXY line on the growth-rate plane. The relation between the growth ratio and growth rate can be expressed as follows:

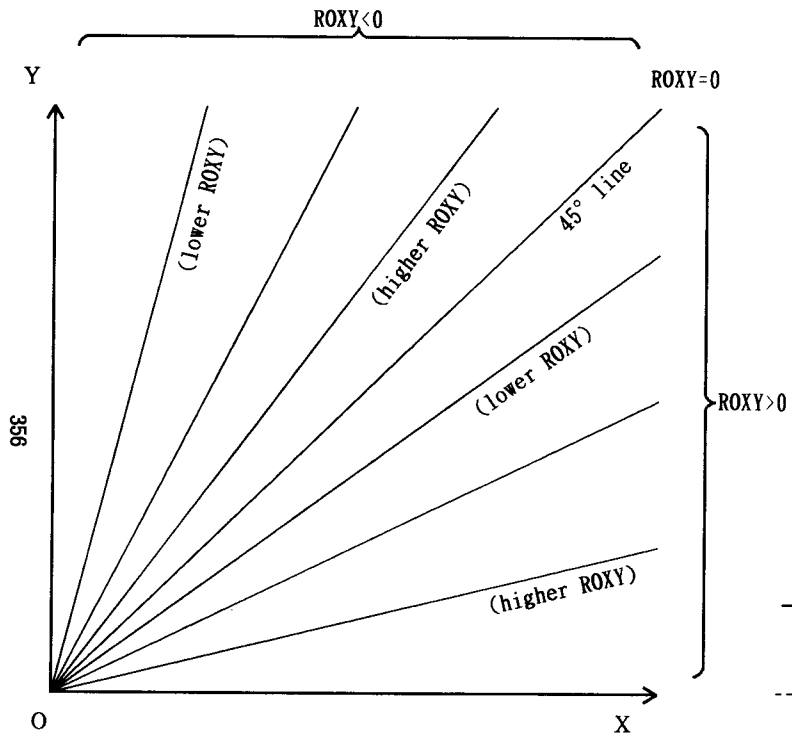

Figure 15 Iso-ROXY Lines on Growth-ratio Plane

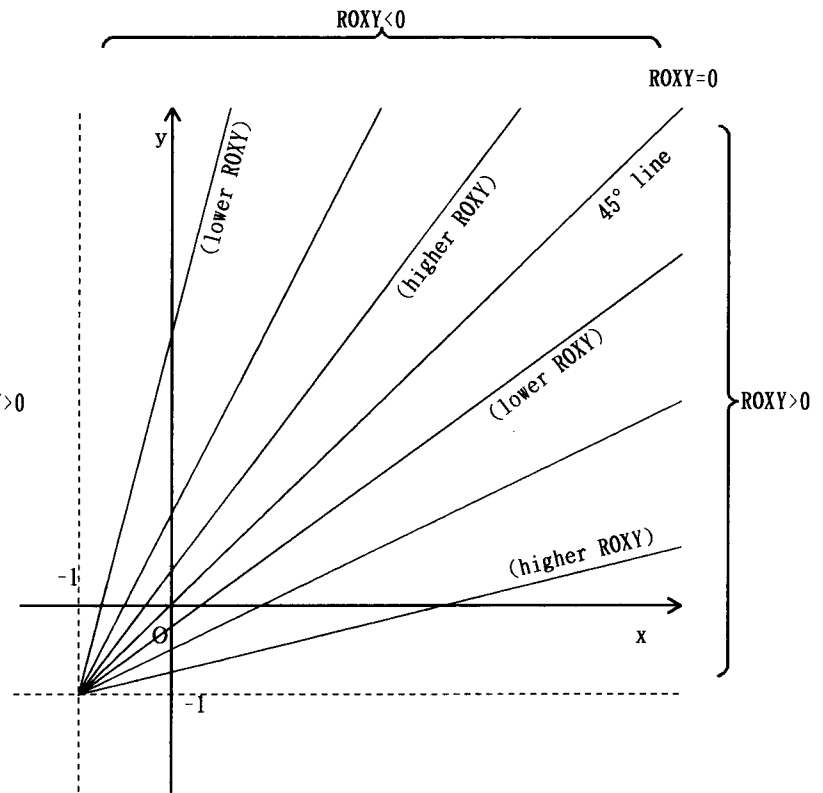

Figure 16 Iso-ROXY Lines on Growth-rate Plane

$$\begin{aligned} x &= \frac{r^{t+1} - r^t}{r^t} \\ &= X - 1 \end{aligned} \tag{1.5}$$

$$y = Y - 1 \tag{1.6}$$

where X : Annual growth rate of population in the center of a metropolitan area
 Y : Annual growth rate of population in the suburbs of the metropolitan area
 r^{t+1}, r^t : Population in years t and $t+1$ respectively.

From equations (1.2), (1.5) and (1.6), the iso-ROXY line on the growth-rate plane can be expressed as follows:

$$(y + 1) = - \frac{R_0 \times 10^{-4} + \frac{S_y - S_x}{S_x + S_y}}{R_0 \times 10^{-4} + \frac{S_x - S_y}{S_x + S_y}} \cdot (x + 1) \tag{1.7}$$

Equation (1.7) shows that the iso-ROXY lines on the growth-rate plane correspond to the lines which the iso-ROXY lines on the growth-ratio plane is transferred to the x direction by -1 and to the y direction by -1 . Therefore, the iso-ROXY lines on the growth-rate plane will be distributed as shown in Figure 16.

From the above discussion on the iso-ROXY lines, it can be known that there exist three groups of trajectories corresponding to the three types of spatial cycles on the ROXY- Δ ROXY plane as shown in Figure 17(a). For the type (i) of the spatial-cycle path in Figure 17(a), it takes the maximum positive value of the ROXY index at A_1 , the minimum negative value at A_3 , and the value of zero at A_2 and A_4 . This corresponds to the trajectories of type (i) on Panels (b) and (c) in Figure 17. For the type (ii) of the spatial-cycle path in Figure 17(a), it takes the maximum positive value at B_1 and the minimum positive value at B_3 . This corresponds to the trajectories of type (ii) on Panels (b) and (c). For the type (iii) of the spatial-cycle path in Figure 17(a), it takes the maximum negative value at C_1 and the minimum negative value at C_3 . This corresponds to the trajectories of type (iii) on Panels (b) and (c).

In the context of Figure 17, our newly found sub-cycles which take place at the DD stage are categorized into the type (iii) of the spatial-cycle path on the ROXY- Δ ROXY plane, and therefore into the type (iii) of trajectories both on the growth-ratio plane (Panel (b)) and on the growth-rate plane (Panel (c)).

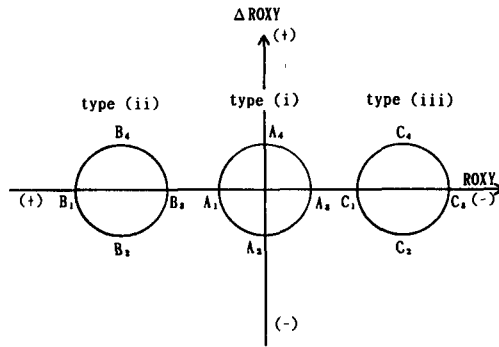

(a) Trajectories on ROXY- Δ ROXY Plane

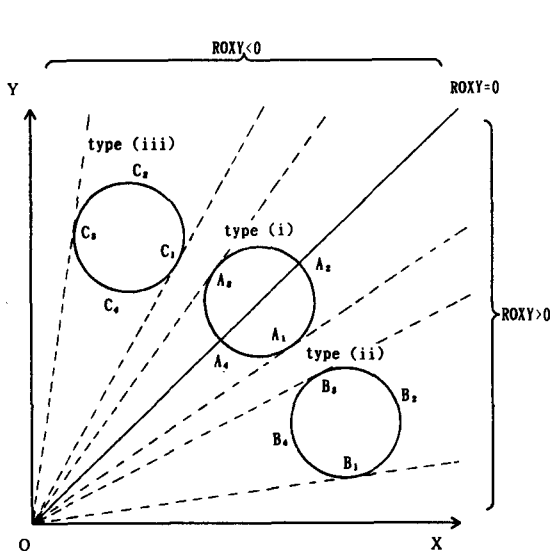

(b) Trajectories on Growth-ratio Plane

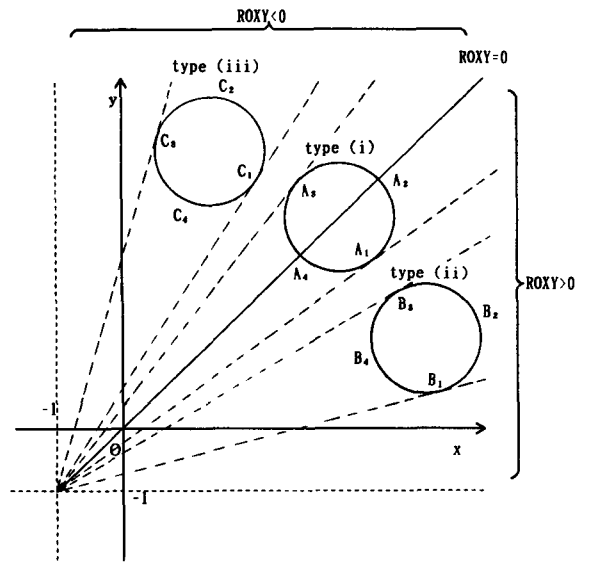

(c) Trajectories on Growth-rate Plane

Figure 17 Three Types of Trajectories on Three Different Planes

2 Eigenvalue Analysis for Periods of Spatial-cycle Paths: Application of Econometric Approach to Values of ROXY Index Obtained for the Stage of Decentralization.

In this section, we try to identify the period of sub-cycles in the DD stage. For this purpose, we apply autoregressive models to the normalized values of three-year-averaged ROXY index for the Chuo-line region in the disaggregated case.

When we assume no trend over time, we have the following results.

AR(1-1) model:

$$\text{NR}(t) = -0.06 + 0.88 \times \text{NR}(t-1)$$

(-0.93) (14.9) $R^2 = 0.88$

AR(2-1) model:

$$\text{NR}(t) = -0.09 + 1.36 \times \text{NR}(t-1) - 0.52 \times \text{NR}(t-2)$$

(-1.70) (8.62) (-3.50) $R^2 = 0.91$

AR(3-1) model:

$$\text{NR}(t) = -0.08 + 1.39 \times \text{NR}(t-1) - 0.53 \times \text{NR}(t-2) - 0.00085 \times \text{NR}(t-3)$$

(-1.45) (6.64) (-1.63) (-0.0046) $R^2 = 0.91$

where NR (t) : Normalized value of the three-year-averaged ROXY index for the Chuo-line region in the disaggregated case (for period between time t and t+1)

R^2 : Coefficient of determination

The t-value of the regression coefficient is shown in the parenthesis.

Therefore, we will adopt the model AR(2-1) in light of the values of R^2 and t.

When we assume the explicit existence of the trend, we have the following result showing the linear relationship between t and NR (t) which we denote by TNR (t);

$$\text{TNR}(t) = -33.9 + 0.017 \times t$$

(-257.3) (5.75) $R^2 = 0.55$

Here, let us introduce the residual of the trend, Z (t), which is defined as:

$$Z(t) = \text{NR}(t) - \text{TNR}(t)$$

Now we apply the autoregression method to $Z(t)$. We then have;

AR(1-2) model:

$$Z(t) = -0.00092 + 0.87 \times Z(t-1) \quad R^2 = 0.74$$

(-0.014) (8.65)

AR(2-2) model:

$$Z(t) = -0.0044 + 1.41 \times Z(t-1) - 0.66 \times Z(t-2) \quad R^2 = 0.85$$

(0.086) (9.43) (-4.35)

AR(3-2) model:

$$Z(t) = -0.08 + 1.39 \times Z(t-1) - 0.53 \times Z(t-2) - 0.00085 \times Z(t-3) \quad R^2 = 0.86$$

(0.071) (6.23) (-1.05) (-1.17)

In light of the magnitude of R^2 and t-value, we adopt the model AR(2-2).

We now calculate the period of the sub-cycle for both AR(2-1) and AR(2-2) models. For the case in which no trend is assumed, the characteristic equation appears as follows:

$$\omega^2 - 1.36\omega + 0.52 = 0$$

Therefore, we obtain the eigenvalue, ω , as follows:

$$\begin{aligned} \omega &= 0.678 \pm 0.471i \\ &= 0.826 \times (0.822 \pm 0.570i) \\ &= 0.826 \times \exp(0.607i) \text{ or } 0.826 \times \exp(-0.607i) \end{aligned}$$

Hence, the period (T_n) of the sub-cycle for the case in which we assume no trend is expressed as:

$$\begin{aligned} T_n &= 2\pi/0.607 \\ &= 10.36 \text{ (years)} \end{aligned}$$

For the case in which we assume the existence of the trend, the characteristic equation appears as follows:

$$\omega^2 - 1.41\omega + 0.66 = 0$$

Therefore, we obtain the eigenvalue, ω , as follows:

$$\begin{aligned}\omega &= 0.703 \pm 0.821i \\ &= 1.08 \times (0.650 \pm 0.760i) \\ &= 1.08 \times \exp(0.863i) \text{ or } 1.08 \times \exp(-0.863i)\end{aligned}$$

Hence, the period (T_s) of the sub-cycle for the case in which we assume trend can be expressed as follows:

$$\begin{aligned}T_s &= 2\pi / 0.863 \\ &= 7.28 \text{ (years)}\end{aligned}$$

The period of the sub-cycle with the assumed existence of the trend is a slightly shorter than that without any trend assumed. It is because NR (t) have to return back to the original value in a period, if we assume no trend. However, if we assume the existence of trend, NR (t) need not return back to the original value as shown in Figure 18.

Part II Theoretically-ideal Formulations of ROXY Index

A good number of attempts have been made to apply the ROXY index in the analyses of the spatial-cycle phenomena concerning the intra- and inter-metropolitan redistribution processes of population and other socio-economic activities since the initial application of the ROXY index in Kawashima (1978). In Part II, picking up the case in which the ROXY index would be applied for the intra-metropolitan analysis, we intend to improve the formulation of a specific type of the ROXY index for which the weighing factor is expressed as a function of the distance of each locality (or subareas) from the central business district (CBD). The values of the ROXY index calculated through the conventional formulation has the dependency on the spatial distribution pattern of subareas, even though this type of the ROXY index has been used for identifying spatial-cycle stages. This would make it relatively difficult for the ROXY index to be applied to cross-sectional intra-metropolitan analyses among different metropolitan areas. Meanwhile, the ROXY index method can be consistently applied to the time-series analyses since the distribution of subareas is usually fixed, though careful consideration is requested on this point because the value of the weighing factor for the ROXY Index is usually asymmetricly distributed in the range between its maximum and minimum values.

At the outset in Part II, the conventional formulation of the ROXY index is examined to point out its drawbacks. Then, the theoretically-ideal new formulations of the ROXY index is proposed. Thirdly, means for approximate calculation of the theoretically-ideal formulations of the ROXY index are suggested. Finally, we apply both conventional and new formulations of the ROXY index to the actual data on population of the Takasaki-line region in the Tokyo metropolitan area, and compare the differences in the values derived through each of the conventional and new formulations of the ROXY index to confirm the acceptable

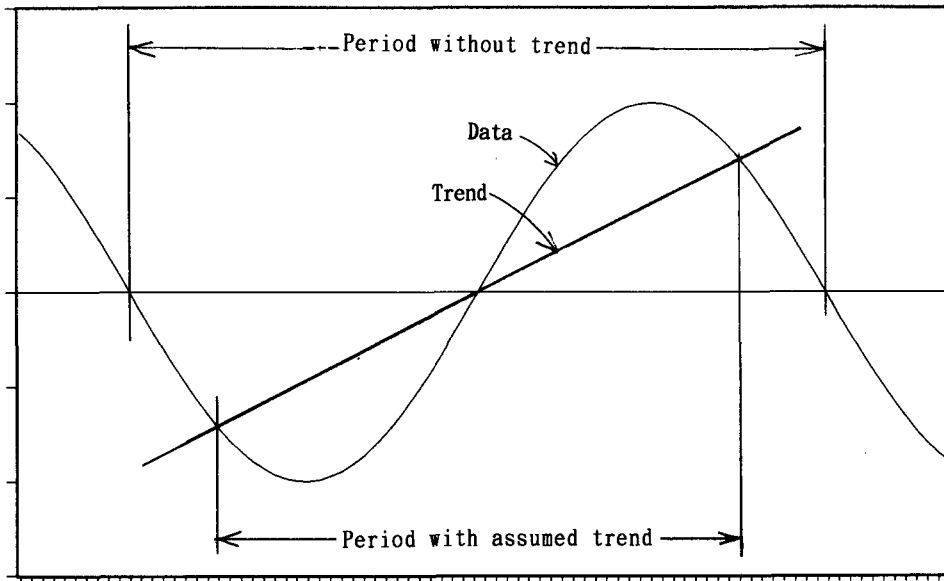

Figure 18 Difference between Period without Trend and Period with Assumed Trend

Table 19 Numerical Example for Showing Dependency of Conventional ROXY Index on Disaggregation of Subareas

(a) Case of aggregated subarea-1

Subarea (i)	Distance from CBD(d_i)	Population at t	Population at t+1	Growth Ratio (r_i^{t+1})
1	2.0	100	90	0.90
2	4.0	100	100	1.00
3	7.0	100	120	1.20
4	12.0	100	130	1.30
5	18.0	100	140	1.40
Total	-	500	580	1.16

(b) Case of disaggregated subarea-1

Subarea (i)	Distance from CBD(d_i)	Population at t	Population at t+1	Growth Ratio (r_i^{t+1})
1a	1.5	50	45	0.90
1b	2.5	50	45	0.90
2	4.0	100	100	1.00
3	7.0	100	120	1.20
4	12.0	100	130	1.30
5	18.0	100	140	1.40
Total	-	500	580	1.16

validity of the newly-constructed formulations of the ROXY index.

3 Conventional Formulation of ROXY Index: Definition and Drawbacks for Discrete-linear Region

3.1 Definition of Conventional ROXY Index

The ROXY index for the period between time t and $t+1$ is conventionally defined as follows;

$$R_c = \left(\frac{\text{Weighted-average growth ratio}}{\text{Simple-average growth ratio}} - 1.0 \right) \times 10^4 \quad (3.1)$$

In identifying the stages of intra-metropolitan spatial-cycle paths, we use the simple and weighted averages of growth ratio which are defined as follows;

$$\text{Simple-average growth ratio} = \frac{\sum_{i=1}^n r_i^{t+1}}{n} \quad (3.2)$$

$$\text{Weighted-average growth ratio} = \frac{\sum_{i=1}^n w(i) r_i^{t+1}}{\sum_{i=1}^n w(i)} \quad (3.3)$$

where

r_i^{t+1} : Population growth ratio of subarea i for the period between time t and $t+1$, where the growth ratio is defined as the population level at time $t+1$ divided by that at time t

$w(i)$: Weighing factor of subarea i

n : Number of subareas

As to the weighing factor, the distance from the subarea i to the CBD, $W_1(i)$, or the reversed distance, $W_2(i)$, has been made use of in the intra-metropolitan ROXY index analyses⁵⁾ with the following definitional connotations;

$$w_1(i) = d_i \quad (3.4)$$

$$\begin{aligned} w_2(i) &= l_i \\ &= d_{\max} + d_{\min} - d_i \end{aligned} \quad (3.5)$$

where

d_i : Distance from the subarea i to the CBD of the central city of the metropolitan area to which that subarea belongs

l_i : Reversed distance of subarea i which is defined as " $d_{\max} + d_{\min} - d_i$ "

d_{\max} : Maximum value of d_i ($i = 1, 2, 3, \dots, n$)

d_{\min} : Minimum value of d_i ($i = 1, 2, 3, \dots, n$)

The value of the ROXY index with the CBD distance as weighing factor, shows the following functional relation with the value of the ROXY index in which the reversed distance is used as weighing factor⁶;

$$R_l = - \frac{\bar{d}}{\bar{l}} \cdot R_d$$

where

R_l : ROXY index with the reversed distance as weighing factor

R_d : ROXY index with the CBD distance as weighing factor

\bar{d} : Average of CBD distances which is defined as $\frac{\sum_{i=1}^n d_i}{n}$

\bar{l} : Average of reversed distances which is defined as $\frac{\sum_{i=1}^n l_i}{n}$ that is equal to " $d_{\max} + d_{\min} - \bar{d}$ "

In light of the aforementioned, it can be understood that the difference between the value of the ROXY index with the reversed distance as weighing factor and that with the CBD distance would not matter basically for our investigation. Therefore, we adopt the ROXY index with the CBD distance as a conventional formulation of the ROXY index in our analysis below. That is, we will stick ourselves for a while to;

$$R_d \equiv \left\{ \frac{\sum_{i=1}^n d_i \cdot r_i^{t+1}}{\sum_{i=1}^n d_i} \cdot \frac{n}{\sum_{i=1}^n r_i^{t+1}} - 1.0 \right\} \times 10^4 \quad (3.7)$$

3.2 Drawbacks of Conventional ROXY Index

There are at least two drawbacks for the conventional ROXY index: (i) dependency on the mutual separation of subareas and (ii) asymmetricity towards the minimum and maximum

values of the weighing factor. These drawbacks are to be caused by the fact that the value of the conventional ROXY index depends on the distribution pattern of the value of the weighing factor for each of subareas despite of the fact that it would be desirable if the value of the ROXY index would depend only on the distribution pattern of growth ratios.

3.2.1 Dependency on Mutual Separation of Subareas

Table 19(a) shows the numerical example as to a metropolitan area with five localities. We assume that localities are located at 2, 4, 7, 12 and 18 km respectively from the CBD. Each of them has the same size of a population of 100 persons at time t , and they have 90, 100, 120, 130 and 140 persons respectively at time $t+1$. The ROXY index for this example can be calculated as follows;

Simple-average growth ratio = 1.16

Weighted-average growth ratio = 1.28

$$R_d = \left(\frac{\text{Weighted-average growth ratio}}{\text{Simple-average growth ratio}} - 1.0 \right) \times 10^4 = 1026.5 \quad (3.8)$$

To compare with this value, we introduce the second numerical example as given by Table 19(b) which shows the dependency of the conventional ROXY index upon how to separate subareas. We assume that the subarea 1 in Table 19(a) is further divided into two sub-subareas, 1a and 1b, which are located at the distance of 1.5 and 2.5 km from the CBD respectively and which have the same levels of population, 50 persons at time t and 45 persons at time $t+1$. Other conditions in Table 19(b) remain the same as in Table 19(a). For this setting, the basic distribution pattern of the population growth ratio in the model of Table 19(b) is identical to that in the example of Table 19(a). The ROXY index of the second example can be calculated as follows;

Simple-average growth ratio = 1.12

Weighted-average growth ratio = 1.26

$$R_d = \left(\frac{\text{Weighted-average growth ratio}}{\text{Simple-average growth ratio}} - 1.0 \right) \times 10^4 = 1303.48 \quad (3.9)$$

What has to be noticed here is that the values of the ROXY index for cases represented by Tables 19(a) and 19(b) are different from each other in spite of the basically identical distribution of the population. It is because the value of the conventional ROXY index is dependent upon how to disaggregate subareas.

3.2.2 Asymmetry of Minimum and Maximum Values for Weighing Factors

The equation (3.7) can be modified into the following equation;

$$R_d = \left(\sum_{i=1}^n a_i \cdot x_i - 1.0 \right) \times 10^4 \quad (3.10)$$

where

$$a_i = \frac{d_i \cdot n}{\sum_{i=1}^n d_i}$$

$$x_i = \frac{r_i^{t+1}}{\sum_{i=1}^n r_i^{t+1}}$$

It is to be noticed that a_i is constant over time for a system of subareas in a given metropolitan area, because a_i is a function of CBD distances of subareas and of the number of subareas. On the other hand, x_i is variable and generally depends on the share of growth ratios in the metropolitan area. Accordingly, the problem for us to tackle is to minimize or maximize the objective function (3.10) having n decision variables of x_i under following constraints;

$$\begin{cases} \sum_{i=1}^n x_i = 1 & (3.11) \\ x_i > 0, \text{ for } \forall x_i & (3.12) \end{cases}$$

Since the objective function and constraints are all linear and any decision variable x_i is supposed to be positive, we can solve this problem by the simplex method. The minimum value is realized when the growth ratio is monopolized by x_i that corresponds to the minimum of a_i , while the maximum value is realized when the growth ratio is monopolized by x_i that corresponds to the maximum of a_i . Since a_i is minimized for the subarea nearest to the CBD and maximized for the subarea farthest from the CBD, we obtain the following solutions;

Minimum value:

$$\begin{aligned} \min (R_d) &= \left\{ \frac{d_{\min} \cdot n}{\sum_{i=1}^n d_i} - 1.0 \right\} \times 10^4 \\ &= \left(\frac{d_{\min}}{\bar{d}} - 1.0 \right) \times 10^4 \end{aligned} \quad (3.13)$$

Maximum value:

$$\begin{aligned} \max (R_d) &= \left\{ \frac{d_{\max} \cdot n}{\sum_{i=1}^n d_i} - 1.0 \right\} \times 10^4 \\ &= \left(\frac{d_{\max}}{\bar{d}} - 1.0 \right) \times 10^4 \end{aligned} \quad (3.14)$$

The above result clearly shows that both of the maximum and minimum values of R_d are dependent upon the spatial distribution pattern of subareas, since the values d_{\min} , d_{\max} and \bar{d} are all closely associated with the spatial distribution pattern of subareas.

The absolute values of equations (3.13) and (3.14), are identical only when $d_{\min} + d_{\max} = 2\bar{d}$. This condition can be achieved in case when we have a uniform distribution of the CBD distance of subareas or when we have a metropolitan area with only two subareas. In empirical analyses for which administrative units are usually employed as subareas, the spatial density of subareas are higher in the central area than in suburbs, because the administrative units in suburbs are usually larger than those in the center. This fact would imply that $d_{\min} + d_{\max} > 2\bar{d}$ and that the degree of the extent of value of ROXY index is asymmetric, namely, the absolute value of the maximum is greater than that of the minimum.

To confirm the asymmetry of the minimum and maximum values of the conventional formulation of the ROXY index, we set up additional two numerical examples of a metropolitan area as shown in Table 20. In these examples, distance of subareas from the CBD is the same as in Table 19 (a). In Table 20 (a), however, the growth ratio of subarea 1 is 2.0 while the growth ratios of other subareas are zero. In Table 20 (b), the growth ratio of subarea 5 is 2.0 and the growth ratios of other subareas are zero.

Based on the above setting, we get the minimum value as follows;

Simple-average growth ratio = 0.400

Weighted-average growth ratio = 0.093

$$R_d = \left(\frac{\text{Weighted-average growth ratio}}{\text{Simple-average growth ratio}} - 1.0 \right) \times 10^4 = -7674.42 \quad (3.15)$$

Table 20 Numerical Example for Showing Asymmetry of Minimum and Maximum Value of Conventional ROXY Index

(a) Case of minimum value

Subarea (i)	Distance from CBD(d_i)	Population at t	Population at t+1	Growth Ratio ($r_i^{t,t+1}$)
1	2.0	100	200	2.0
2	4.0	100	0	0.0
3	7.0	100	0	0.0
4	12.0	100	0	0.0
5	18.0	100	0	0.0
Total	-	500	200	0.4

(b) Case of maximum value

Subarea (i)	Distance from CBD(d_i)	Population at t	Population at t+1	Growth Ratio ($r_i^{t,t+1}$)
1	2.0	100	0	0.0
2	4.0	100	0	0.0
3	7.0	100	0	0.0
4	12.0	100	0	0.0
5	18.0	100	200	2.0
Total	-	500	200	0.4

Using the growth ratio in Table 2-(b), we get the maximum value as follows;

$$\begin{aligned}
 &\text{Simple-average growth ratio} = 0.400 \\
 &\text{Weighted-average growth ratio} = 0.837 \\
 &R_d = \left(\frac{\text{Weighted-average growth ratio}}{\text{Simple-average growth ratio}} - 1.0 \right) \times 10^4 = 10940.23 \quad (3.16)
 \end{aligned}$$

The above results show the asymmetry of the value of the conventional ROXY index toward its minimum and maximum. Since, reflecting the distribution of actual administrative units, the spatial density of subareas are generally higher in the center than in the suburbs, the absolute value of the maximum of the conventional ROXY index usually tends to be greater than that of the minimum. Since the value of conventional ROXY index has a dependency on the distribution of subareas as having been seen above, there still is a room for considerable studies to improve the formulation of the ROXY index in such a way that we can more reasonably apply the ROXY-index method for intra-metropolitan comparative analyses among different metropolitan areas.

4 Theoretically-ideal Formulations of ROXY Index: Definition, Normalization, and Interpretations for One-dimensional Continuous-linear Region and Two-dimensional Fan-shaped Region

4.1 Aim of Investigation on Theoretically-ideal Formulations of ROXY Index

Though the conventional formulation of the ROXY index has two major drawbacks, little studies have ever been tried to tackle with these drawbacks. The purpose of this section is to construct the idealistically normalized ROXY index. We first introduce two kinds of ideal ROXY indices, which have no dependence on the spatial distribution of subareas, with the assumption of the continuous distribution of growth ratios. Secondly, we investigate the weighing factors to make the ideal ROXY indices symmetric, and then construct the means to normalize the ideal ROXY indices. Thirdly, we discuss on the positions of the boundary between the core and ring⁷⁾ to provide more profound interpretations of the value of the ROXY index.

4.2 Definition of Ideal ROXY Index

Here, we define two types of the ideal ROXY indices. The one is set for the one-dimensional continuous-linear region, as shown in Figure 19, and the other is for the two-dimensional fan-shaped region, as shown in Figure 20. In the analysis of the bundle of a whole metropolitan area, the ROXY index for the two-dimensional fan-shaped region may be appropriate, since the larger the quantity of land becomes as the distance from the CBD

becomes farther. On the other hand for the analysis of a partial area of a metropolis, the ROXY index for the one-dimensional continuous-linear region may be appropriate if the shape of the partial area appears like the shape of a leaf as shown in Figure 21 to represent, for example, a region composed of localities situated along a certain railway line.

4.2.1 Idealistic ROXY Index for One-dimensional Continuous-linear Region

To construct an idealistic ROXY index, the continuous growth ratio, $r_L^{t,t+1}(x)$, is to be introduced. This ratio is defined over the distance x within a given range, and its definition is provided as follows;

$$r_L^{t,t+1}(x) \equiv \frac{n_L^{t+1}(x)}{n_L^t(x)} \quad (4.1)$$

where

$r_L^{t,t+1}(x)$: Population growth ratio at distance x in the one-dimensional continuous-linear region for the period between time t and $t+1$

$n_L^t(x)$: Population density at the distance x in the one-dimensional continuous-linear region at time t^0

$n_L^{t+1}(x)$: Population density at distance x in the one-dimensional continuous-linear region at time $t+1$

x : Distance to the CBD of the central city of a metropolitan area

Using the above continuous growth ratio, the simple average of the continuous growth ratio over the distance x is equal to:

$$\frac{\int_{d_0}^{d_1} r_L^{t,t+1}(x) dx}{\int_{d_0}^{d_1} dx} \quad (4.2)$$

where

d_0 : Nearest distance to the center

d_1 : Farthest distance to the center

The weighted average of the continuous growth ratio over the distance x is equal to:

$$\frac{\int_{d_0}^{d_1} w(x) r_L^{t,t+1}(x) dx}{\int_{d_0}^{d_1} w(x) dx} \quad (4.3)$$

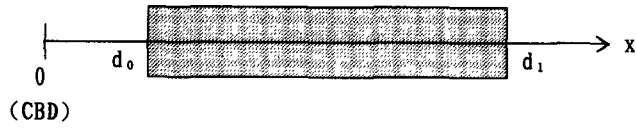

Figure 19 Image of One-dimensional Continuous-linear Region

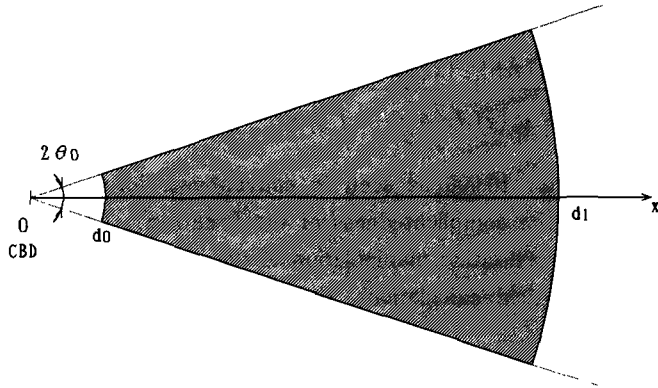

Figure 20 Image of Two-dimensional Fan-shaped Region

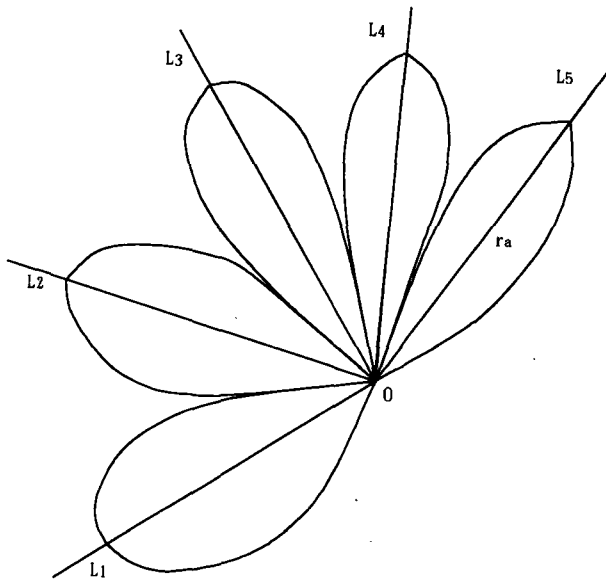

Figure 21 Leaflike-shape of Partial Areas in a Metropolitan Area

where

$w(x)$: Weighing factor which is continuously defined over the distance x

Using the simple and weighted averages of the continuous growth ratio, the idealistic ROXY index, R_L , can therefore be defined as follows;

$$R_L \equiv \frac{\text{Weighted-average of growth ratio}}{\text{Simple-average of growth ratio}} - 1.0$$

$$= \frac{\int_{d_0}^{d_1} w(x) r_L^{t,t+1}(x) dx}{\int_{d_0}^{d_1} w(x) dx} \cdot \frac{\int_{d_0}^{d_1} dx}{\int_{d_0}^{d_1} r_L^{t,t+1}(x) dx} - 1.0 \quad (4.4)$$

Hereafter, the scaling factor 10,000 as seen in conventional formulation equation (3.1), is omitted in order to avoid the complicatedness of the formulae. The scaling factor will be later on restored in the normalization manipulation of the ideal ROXY index.

After necessary analytical calculations, the ideal ROXY index can be found to be expressed as follows;

$$R_L = \frac{(d_1 - d_0) \cdot \int_{d_0}^{d_1} w(x) r_L^{t,t+1}(x) dx}{\int_{d_0}^{d_1} w(x) dx \cdot \int_{d_0}^{d_1} r_L^{t,t+1}(x) dx} - 1.0 \quad (4.5)$$

4.2.2 Idealistic ROXY Index for Two-dimensional Fan-shaped Region

Taking the similar process as for the one-dimensional continuous-linear region, we construct the ideal ROXY index for the two-dimensional fan-shaped region. For this purpose let us introduce the continuous growth ratio, $r_F^{t,t+1}(x, \theta)$, which is defined all over the distance x and the angle θ within a given area. The definition of the continuous growth ratio is given as follows;

$$r_F^{t,t+1}(x, \theta) \equiv \frac{n_F^{t+1}(x, \theta)}{n_F^t(x, \theta)} \quad (4.6)$$

where

$r_F^{t,t+1}(x, \theta)$: Population growth ratio at distance x and angle θ in the two-dimensional fan-shaped region for the period between time t and $t+1$

$r_F^t(x, \theta)$: Population density at the distance x and angle θ in the two-dimensional fan-shaped region at time t^0 .

$r_F^{t+1}(x, \theta)$: Population density at distance x and angle θ in the two-dimensional fan-shaped region at time $t+1$

x : Distance to the CBD of the central city of a metropolitan area
 θ : Angle from the central axis through the CBD

The simple average of the continuous growth ratio over the distance x and the angle θ would be equal to;

$$\frac{\int_{d_0}^{d_1} \int_{-\theta_0}^{\theta_0} r_F^{t,t+1}(x, \theta) \cdot x d\theta dx}{\int_{d_0}^{d_1} \int_{-\theta_0}^{\theta_0} x d\theta dx} \quad (4.7)$$

where θ_0 : Half of the central angle of a fan-shaped region

The weighted average would be equal to;

$$\frac{\int_{d_0}^{d_1} \int_{-\theta_0}^{\theta_0} w(x) r_F^{t,t+1}(x, \theta) \cdot x d\theta dx}{\int_{d_0}^{d_1} \int_{-\theta_0}^{\theta_0} w(x) x d\theta dx} \quad (4.8)$$

Using the simple and weighted average of the continuous growth ratios, the ideal ROXY index, R_F , can be given as follows;

$$\begin{aligned} R_F &\equiv \frac{\text{Weighted average of growth ratio}}{\text{Simple average of growth ratio}} - 1.0 \\ &= \frac{\int_{d_0}^{d_1} \int_{-\theta_0}^{\theta_0} w(x) r_F^{t,t+1}(x, \theta) x d\theta dx \cdot \int_{d_0}^{d_1} \int_{-\theta_0}^{\theta_0} x d\theta dx}{\int_{d_0}^{d_1} \int_{-\theta_0}^{\theta_0} w(x) x d\theta dx \cdot \int_{d_0}^{d_1} \int_{-\theta_0}^{\theta_0} r_F^{t,t+1}(x, \theta) x d\theta dx} - 1.0 \end{aligned} \quad (4.9)$$

After necessary calculations, we can obtain the ideal ROXY index expressed as follows;

$$R_F = \frac{(d_1^2 - d_0^2) \cdot \int_{d_0}^{d_1} \int_{-\theta_0}^{\theta_0} w(x) r_F^{t,t+1}(x, \theta) x d\theta dx}{2 \cdot \int_{d_0}^{d_1} w(x) x dx \cdot \int_{d_0}^{d_1} \int_{-\theta_0}^{\theta_0} r_F^{t,t+1}(x, \theta) x d\theta dx} - 1.0 \quad (4.10)$$

If we assume that the continuous growth ratio is not dependent on the angle θ , the integral by the angle θ can be performed as follows;

$$R_F = \frac{(d_1^2 - d_0^2) \cdot \int_{d_0}^{d_1} w(x) r_F^{t,t+1}(x) x dx}{2 \cdot \int_{d_0}^{d_1} w(x) x dx \cdot \int_{d_0}^{d_1} r_F^{t,t+1}(x) x dx} - 1.0 \quad (4.11)$$

where

$r_F^{t,t+1}(x)$: Population growth ratio at distance x which is independent of the angle θ , for the period between time t and $t+1$

In the analysis of the intra-metropolitan redistribution of population, a considerable number of studies have been made on the redistribution along the direction x . For example, we have the study on the spatial-cycle hypothesis by Klaassen and Paelinck (1979) and Klaassen et al. (1981). No attempts in these studies have so far been made on the redistribution along the direction θ .

4.3 Normalization of Theoretically-ideal ROXY Index

In this section, the maximum and minimum values of the ideal ROXY indices defined in the previous section, are first calculated. Then, the weighing factors are selected so as to make the absolute values of the maximum and minimum to become equal. Thirdly, we try to normalize the ideal ROXY index.

4.3.1 Normalization of Theoretically-ideal ROXY Index for One-dimensional Continuous-linear Region

A weighing factor of the ROXY index employed in the analysis of the phenomena of the spatial centralization and decentralization, must be a single-valued monotonous function over the direction x . Unless a weighing factor is a single-valued monotonous function, the tendency of the spatial centralization and decentralization can not be revealed simply. In addition to the single-valued and monotonous features, the continuous and differentiable characteristics of the weighing factor is to be assumed in order to make the weighing factor mathematically tractable.

Based on the above assumptions, we further assume that the weighing factor is strictly and monotonously increasing over the distance x as indicated by;

$$\frac{dw(x)}{dx} > 0 \text{ for } \forall x \text{ in a given area} \quad (4.12)$$

Under the above condition, it can be easily found that the minimum value is realized when

the growth ratio is monopolized at the minimum distance d_0 and that the maximum value is realized when the growth ratio is monopolized at the maximum distance d_1 . Accordingly, the distribution of the growth ratios for the maximum and minimum values of the ROXY index would be formulated as follows;

$$r_{L, \text{MIN}}(x) = 2P \cdot \delta(x - d_0) \quad (4.13)$$

$$r_{L, \text{MAX}}(x) = 2P \cdot \delta(x - d_1) \quad (4.14)$$

where

$r_{L, \text{MIN}}(x)$: Distribution of the growth ratio to realize the minimum value of the idealistic ROXY index for the one-dimensional continuous-linear region

$r_{L, \text{MAX}}(x)$: Distribution of the growth ratio to realize the maximum value of the idealistic ROXY index for the one-dimensional continuous-linear region

P : Total growth ratio in a metropolitan area which is defined as

$$\int_{d_0}^{d_1} r_{L, t, t+1}(x) dx$$

$\delta(x)$: Dirac's delta function¹⁰⁾

Substituting $r_{L, \text{MIN}}(x)$ in equation (4.13) to $r_L^{t, t+1}(x)$ in equation (4.5), we obtain the minimum value of R_L as follows;

$$\begin{aligned} \min(R_L) &\equiv \frac{(d_1 - d_0) \cdot \int_{d_0}^{d_1} w(x) \cdot 2P\delta(x - d_0) dx}{\int_{d_0}^{d_1} w(x) dx \cdot \int_{d_0}^{d_1} 2P\delta(x - d_0) dx} - 1.0 \\ &= \frac{(d_1 - d_0) \cdot w(d_0)}{\int_{d_0}^{d_1} w(x) dx} - 1.0 \end{aligned} \quad (4.15)$$

Substituting $r_{L, \text{MAX}}(x)$ in equation (4.14) to $r_L^{t, t+1}(x)$ in equation (4.5), we obtain the maximum value of R_L as follows;

$$\begin{aligned} \max(R_L) &\equiv \frac{(d_1 - d_0) \cdot \int_{d_0}^{d_1} w(x) \cdot 2P\delta(x - d_1) dx}{\int_{d_0}^{d_1} w(x) dx \cdot \int_{d_0}^{d_1} 2P\delta(x - d_1) dx} - 1.0 \\ &= \frac{(d_1 - d_0) \cdot w(d_1)}{\int_{d_0}^{d_1} w(x) dx} - 1.0 \end{aligned} \quad (4.16)$$

To equalize the absolute value of the maximum to the absolute value of the minimum, an identical equation $|\min(R_L)| = |\max(R_L)|$ must be satisfied. Substituting $\min(R_L)$ and $\max(R_L)$ in equations (4.15) and (4.16), we get

$$1.0 - \frac{(d_1 - d_0) \cdot w(d_0)}{\int_{d_0}^{d_1} w(x) dx} = \frac{(d_1 - d_0) \cdot w(d_1)}{\int_{d_0}^{d_1} w(x) dx} - 1.0 \quad (4.17)$$

Hence, equation (4.17) turns out to be as follows;

$$(d_1 - d_0) \cdot (w(d_1) + w(d_0)) = 2 \int_{d_0}^{d_1} w(x) dx \quad (4.18)$$

Differentiating equation (4.11) by d_1 and substituting x for d_1 , we obtain

$$\frac{1}{w(x) + w(d_0)} \cdot \frac{dw(x)}{dx} = \frac{1}{x - d_0} \quad (4.19)$$

Solving the differential equation (4.19), the weighing function which equalize the absolute values of the maximum and the minimum, can be obtained as follows;

$$w(x) = Ax + B \quad (4.20)$$

where A and B are integral constants which are independent of the distance x .

Substituting the weighing factor in equation (4.20) to that in equations (4.15) and (4.16), we obtain the minimum and maximum values of R_L as follows;

$$\min(R_L) = - \frac{(d_1 - d_0)A}{(d_1 + d_0)A + 2B} \quad (4.21)$$

$$\max(R_L) = \frac{(d_1 - d_0)A}{(d_1 + d_0)A + 2B} \quad (4.22)$$

With the help of the above investigation, the normalized ideal ROXY index for the one-dimensional continuous-linear region, R_{LN} , can be defined as follows;

$$\begin{aligned}
 R_{LN} &\equiv \left\{ \frac{(d_1 - d_0) \cdot \int_{d_0}^{d_1} (Ax + B) \cdot r_{L^t, t+1}(x) dx}{\int_{d_0}^{d_1} (Ax + B) dx \cdot \int_{d_0}^{d_1} r_{L^t, t+1}(x) dx} - 1.0 \right\} \\
 &\times \frac{(d_1 + d_0)A + 2B}{(d_1 - d_0)} \times 10^4 \\
 &= \left\{ \frac{2}{(d_1 + d_0)A + 2B} \cdot \frac{\int_{d_0}^{d_1} (Ax + B) \cdot r_{L^t, t+1}(x) dx}{\int_{d_0}^{d_1} r_{L^t, t+1}(x) dx} - 1.0 \right\} \\
 &\times \frac{(d_1 + d_0)A + 2B}{(d_1 - d_0)} \times 10^4 \tag{4.23}
 \end{aligned}$$

For the purpose of mathematical tractability, we choose the weighing factor of $w(x) = x$, resulting in that A equals to unity and B equals to zero. Our normalized ideal ROXY index for the one-dimensional continuous-linear region is therefore expressed as follows;

$$R_{LN} = \left\{ \frac{2 \int_{d_0}^{d_1} x r_{L^t, t+1}(x) dx}{(d_1 + d_0) \int_{d_0}^{d_1} r_{L^t, t+1}(x) dx} - 1.0 \right\} \times \frac{d_1 + d_0}{d_1 - d_0} \times 10^4 \tag{4.24}$$

Accordingly, the maximum value of the ROXY index defined by equation (4.24) is equal to +10,000 and the minimum value is equal to -10,000.

4.3.2 Normalization of Theoretically-ideal ROXY Index for Two-dimensional Fan-shaped Region

Taking the similar process as we took for the one-dimensional continuous-linear region, the normalization of the idealistic ROXY index for the two-dimensional fan-shaped region can be achieved. The distributions of the growth ratios for the maximum and minimum values are formulated as follows;

$$r_{F, \text{MIN}}(x) = 2P \cdot \delta(x - d_0) / x \quad (4.25)$$

$$r_{F, \text{MAX}}(x) = 2P \cdot \delta(x - d_1) / x \quad (4.26)$$

Substituting $r_{F, \text{MIN}}(x)$ in equation (4.20) to $r^{\frac{1}{2} + 1}(x)$ in equation (4.6), we obtain the minimum value of R_F as follows;

$$\min(R_F) = \frac{(d_1^2 - d_0^2) \cdot w(d_0)}{2 \int_{d_0}^{d_1} x \cdot w(x) dx} - 1.0 \quad (4.27)$$

Substituting $r_{F, \text{MAX}}(x)$ in equation (4.26) to $r^{\frac{1}{2} + 1}(x)$ in equation (4.11), we obtain the maximum value of R_F as follows;

$$\max(R_F) = \frac{(d_1^2 - d_0^2) \cdot w(d_1)}{2 \int_{d_0}^{d_1} x \cdot w(x) dx} - 1.0 \quad (4.28)$$

To equalize the absolute value of the maximum to the absolute value of the minimum, an identical equation $|\min(R_F)| = |\max(R_F)|$ must be satisfied. Substituting $\min(R_F)$ and $\max(R_F)$ in equations (4.27) and (4.28), we have;

$$1.0 - \frac{(d_1^2 - d_0^2) \cdot w(d_0)}{2 \int_{d_0}^{d_1} x \cdot w(x) dx} = \frac{(d_1^2 - d_0^2) \cdot w(d_1)}{2 \int_{d_0}^{d_1} x \cdot w(x) dx} - 1.0 \quad (4.29)$$

Equation (4.29) then turns out to be;

$$(d_1^2 - d_0^2) \cdot (w(d_0) + w(d_1)) = 4 \int_{d_0}^{d_1} x \cdot w(x) dx \quad (4.30)$$

Differentiating equation (4.30) by d_1 and substituting x for d_1 , we have;

$$\frac{1}{w(x) - w(d_0)} \cdot \frac{dw(x)}{dx} = \frac{2x}{x^2 - d_0^2} \quad (4.31)$$

Solving the differential equation (4.31), the weighing function, which equalizes the absolute value of the maximum and the minimum, can be obtained as follows;

$$w(x) = Ax^2 + B \quad (4.32)$$

where A and B are integral constants which are independent of the distance x.

Substituting the weighing factor of equation (4.32) to that of equations (4.27) and (4.28), we obtain the minimum and maximum values of R_F as follows;

$$\min(R_F) = - \frac{A(d_1^2 - d_0^2)}{A(d_1^2 + d_0^2) + 2B} \quad (4.33)$$

$$\max(R_F) = \frac{A(d_1^2 - d_0^2)}{A(d_1^2 + d_0^2) + 2B} \quad (4.34)$$

With the help of the above investigation, the normalized idealistic ROXY index for the two-dimensional fan-shaped region, R_{FN} , can be defined as follows;

$$\begin{aligned} R_{FN} &\equiv \left\{ \frac{(d_1^2 - d_0^2) \cdot \int_{d_0}^{d_1} (Ax^2 + B) \cdot r_F^{t, t+1}(x) x dx}{\int_{d_0}^{d_1} (Ax^2 + B) x dx \cdot \int_{d_0}^{d_1} r_F^{t, t+1}(x) x dx} - 1.0 \right\} \\ &\times \frac{A(d_1^2 + d_0^2) + 2B}{A(d_1^2 - d_0^2)} \times 10^4 \\ &= \left\{ \frac{2}{(d_1^2 + d_0^2)A + 2B} \cdot \frac{\int_{d_0}^{d_1} (Ax^2 + B) \cdot r_F^{t, t+1}(x) x dx}{\int_{d_0}^{d_1} r_F^{t, t+1}(x) x dx} - 1.0 \right\} \\ &\times \frac{A(d_1^2 + d_0^2) + 2B}{A(d_1^2 - d_0^2)} \times 10^4 \quad (4.35) \end{aligned}$$

For the purpose of mathematical tractability, we choose the weighing factor of $w(x) = x^2$, resulting in that A equals to unity and B equals to zero. Our normalized ideal ROXY index for the two-dimensional fan-shaped region is therefore expressed as follows;

$$R_{FN} = \left\{ \frac{2}{d_1^2 + d_0^2} \cdot \frac{\int_{d_0}^{d_1} r_{F,t,t+1}(x) x^3 dx}{\int_{d_0}^{d_1} r_{L,t,t+1}(x) dx} - 1.0 \right\} \\ \times \frac{d_1^2 + d_0^2}{d_1^2 - d_0^2} \times 10^4 \quad (4.36)$$

Accordingly, the maximum value of the ROXY index defined by equation (4.36) is equal to +10,000 and the minimum value is equal to -10,000.

4.4 Boundary between Core and Ring for Theoretically-ideal ROXY Index

The ideal ROXY index has a negative sign for the stage of centralization of population and positive sign for the stage of decentralization of population. We can therefore reasonably define that, assuming the growth ratio distribution to be expressed by $2G \cdot \delta(x-a)$, the position of the distance $x = a$ belongs to the core if the ROXY index is negative and to the ring if the ROXY index is positive. In order to find the position of the boundary dividing the core and ring, we should search for the position of the distance $x = a$ that makes the value of the ROXY index zero.

Substituting $2G \cdot \delta(x-a)$ to the normalized ideal ROXY index for the one-dimensional continuous-linear region in equation (4.18), and equalizing the ROXY index to zero, we obtain;

$$\frac{2(Aa + B) \cdot (d_1 - d_0)}{(d_1^2 - d_0^2)A + 2(d_1 - d_0)B} - 1 = 0 \quad (4.37)$$

Solving equation (4.27) for a , we have;

$$a = \frac{1}{2} (d_0 + d_1) \quad (4.38)$$

This result implies that the core-ring boundary for the one-dimensional continuous-linear region is delineated at the midpoint of the nearest and farthest distances.

Substituting $2G \cdot \delta(x-a)/x$ to the normalized ideal ROXY index for the two-dimensional fan-shaped region in equation (4.35), and equalizing the ROXY index to zero, we obtain;

$$\frac{2(Aa^2 + B)}{A(d_1^2 - d_0^2) + 2B} - 1 = 0 \quad (4.39)$$

Solving the equation (4.39) for a , we have;

$$a = \frac{\sqrt{2}}{2} \times \sqrt{d_1^2 + d_0^2} \quad (4.40)$$

This result means that the total area of the fan-shaped urban region is divided into halves for the ring and core, and that the area-sizes of the ring and core are both equal to;

$$\frac{\theta (d_1^2 - d_0^2)}{4}$$

It is therefore implied that the core-ring boundary for the two-dimensional fan-shaped region is delineated at somewhat outer distance from the CBD than that for the one-dimensional continuous-liner region.

The important point to be emphasized here is that, since the position of the boundary dividing the "core" and "ring" is dependent on the formulation of the weighing function, if we want to move the core-ring boundary to other position than the position expressed by equations (4.39) or (4.40), we usually have to sacrifice the symmetry property of the normalized theoretically-ideal ROXY index.

4.5 Various Interpretations on ROXY Index

In this subsection, we briefly discuss on four selected terminologies which would play important roles for the understanding of our investigation on the ROXY index in the present paper.

4.5.1 Ratio of "Weighted-Average Growth Ratio" to "Simple-Average Growth Ratio"

The ratio of the weighted-average growth ratio to the simple-average growth ratio is the most substantial element in conceptualizing the structure of the ROXY index. The appropriate choice of the weighing factor for the calculation of the weighted-average growth ratio, would have a critical effects upon the interpretations of the obtained values of the ROXY index.

4.5.2 Slope of Regression Equation Modified to be Scale-invariant for Weighing Factor

The relationship between the value of the conventional ROXY index and the slope of a regression equation, is investigated in Kawashima (1986a) in which he tries to correlate the CBD distance to the growth rate of population of subareas in the Tokyo metropolitan area. With this connection, suppose we have a regression equation;

$$r(x) = \alpha + \beta \times w(x) + e \quad (4.41)$$

where

- $r(x)$: Population growth ratio at distance x
- $w(x)$: Weighing factor at distance x
- α : Regression coefficient for the intercept
- β : Regression coefficient for the slope
- e : Error term

The best linear unbiased estimator for β in equation (4.41) would turn out to be;

$$\frac{n \sum_{i=1}^n w(x_i) \cdot r(x_i) - \sum_{i=1}^n w(x_i) \times r(x_i) - \sum_{i=1}^n r(x_i)}{n \sum_{i=1}^n w(x_i)^2 - \left(n \sum_{i=1}^n w(x_i) \right)^2} \quad (4.42)$$

Therefore, it can be seen that the value of the conventional formulation of the ROXY index and the best linear unbiased estimation for β , both have the same signs, and that the value of the ROXY index is independent of the scaling of the weighing factor while the estimated coefficient for β varies depending on the scaling factor.

Replacing the summation by the integral in equation (4.42), we know that the value of the newly formulated theoretically-ideal ROXY index have the same relation to the estimated coefficient for β as the value of the conventional ROXY index has.

4.5.3 Deviation of Weighted Average for Growth Ratio from Simple Average

The definition of the theoretically-ideal ROXY index for the one-dimensional continuous-linear region as expressed by equation (4.4) can be rewritten as follows;

$$\begin{aligned} R_L &= \frac{\int_{d_0}^{d_1} w(x) \cdot r_L^{t,t+1}(x) dx}{\int_{d_0}^{d_1} w(x) dx} \cdot \frac{1}{\bar{r}_L} - 1.0 \\ &= \frac{\int_{d_0}^{d_1} w(x) \cdot (r_L^{t,t+1}(x) - \bar{r}_L) dx}{\bar{r}_L \cdot \int_{d_0}^{d_1} w(x) dx} \end{aligned} \quad (4.43)$$

where

\bar{r}_L : Simple average of the growth ratio for the one-dimensional continuous-linear region which is defined as

$$\frac{\int_{d_0}^{d_1} r_L^{t,t+1}(x) dx}{\int_{d_0}^{d_1} dx}$$

The definition of the idealistic ROXY index for the two-dimensional fan-shaped region as expressed by equation (4.9) can be, meanwhile, rewritten as follows;

$$R_F = \frac{\int_{d_0}^{d_1} w(x) \cdot (r_F^{t,t+1}(x) - \bar{r}_F) x d\theta dx}{\bar{r}_F \cdot \int_{d_0}^{d_1} w(x) x d\theta dx} \quad (4.44)$$

where

\bar{r}_F : Simple average of the growth ratio for the two-dimensional fan-shaped region which is defined as

$$\frac{\int_{d_0}^{d_1} \int_{-\theta_0}^{\theta_0} r_F^{t,t+1}(x, \theta) x d\theta dx}{\int_{d_0}^{d_1} \int_{-\theta_0}^{\theta_0} x d\theta dx}$$

Since $(r_L^{t,t+1}(x) - \bar{r}_L)$ and $(r_F^{t,t+1}(x) - \bar{r}_F)$ respectively represent the deviation of the growth ratio at x from the simple average as shown in Figure 22, the ROXY index can be interpreted as the weighted deviation of the growth ratio from the simple average after its (*i.e.*, the weighted deviation) normalization through the simple average of \bar{r}_L and \bar{r}_F .

4.5.4 Relative Position of Centroid of Growth Ratio to Center of Distance

The definition of the normalized ideal ROXY index for the one-dimensional continuous-linear region as expressed by equation (4.24), can be rewritten as follows if we omit the scaling factor;

$$R_{LN} = \frac{2}{d_0 + d_1} \cdot x_G - 1 \quad (4.45)$$

where

x_G : Position of the centroid of the growth ratio which is defined as

$$\frac{\int_{d_0}^{d_1} r_L^{t,t+1}(x) x dx}{\int_{d_0}^{d_1} r_L^{t,t+1}(x) dx}$$

This equation implies that the value of the ROXY index is zero when the position of the centroid is located at $\frac{d_0 + d_1}{2}$, positive when located on the farther side of $\frac{d_0 + d_1}{2}$, and negative when located on the nearer side of $\frac{d_0 + d_1}{2}$.

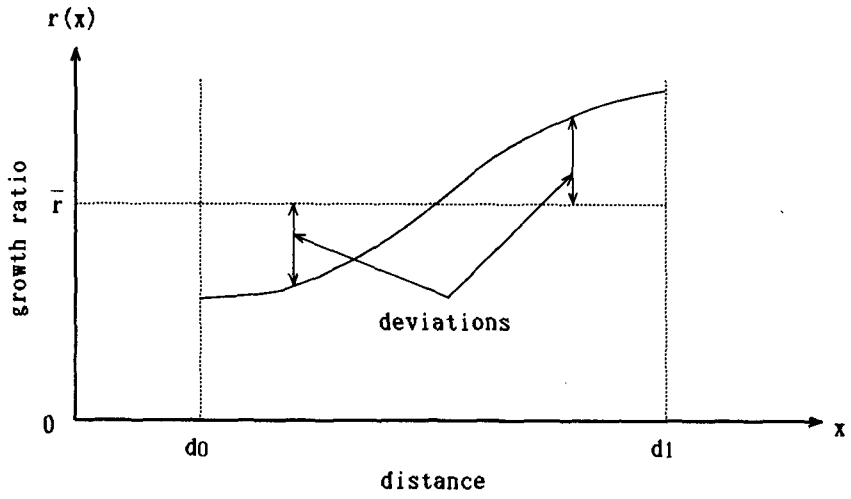

Figure 22 Deviation of $r(x)$ from \bar{r}

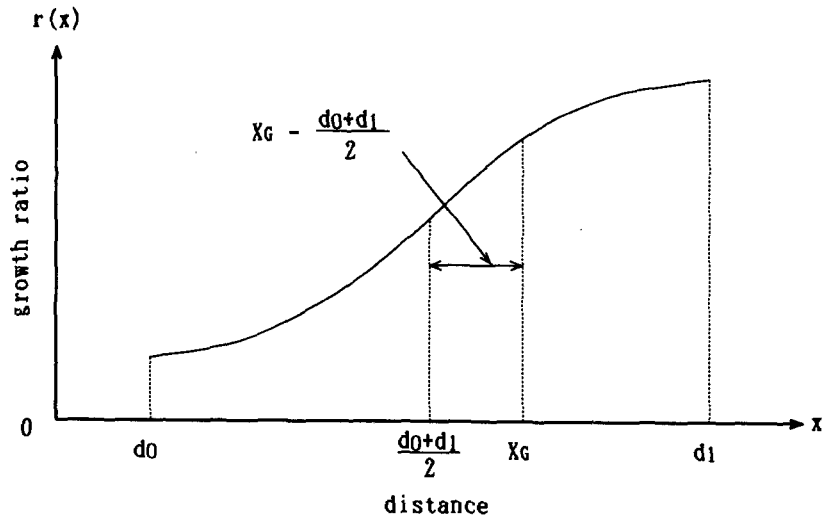

Figure 23 Relative Position of Centroid x_G of $r(x)$ to $\frac{d_0+d_1}{2}$

Therefore, the normalized ideal ROXY index for the one-dimensional continuous-linear region can be interpreted as the relative position of the centroid of the growth ratio to the center of the distance, as shown in Figure 23, after its normalization through the distance of the center.

5 Suggested Formulations of ROXY Index: Approximation Means for Continuous-linear Region and Fan-shaped Region

Though we have investigated the two types of the theoretically-ideal ROXY index rather intensively, the ideal ROXY indices cannot be easily applicable to actual data. It is because the actual data of the growth ratio is aggregated for each administrative units which are spatially distributed in a discrete way but not in a continuous way. Therefore, we must develop the approximation method to calculate the ROXY index for the actual data.

In this chapter, we first discuss the approximation method leading to the formulation of the conventional ROXY index. Then, we discuss the two approximation methods, for the theoretically-ideal ROXY index.

5.1 Approximation Means Leading to Conventional ROXY Index

The theoretically-ideal ROXY index for the one-dimensional continuous-linear region has been constructed as follows (as can be expressed by equations (4.4) and (4.43));

$$R_L = \frac{\int_{d_0}^{d_1} w(x) \cdot r_L^{t,t+1}(x) dx}{\int_{d_0}^{d_1} w(x) dx} \cdot \frac{\int_{d_0}^{d_1} dx}{\int_{d_0}^{d_1} r_L^{t,t+1}(x) dx} - 1.0 \quad (4.4)$$

Four integrals appearing in the above equation can perhaps be approximated as follows;

$$\begin{aligned} \int_{d_0}^{d_1} dx &\approx \sum_{i=1}^n \Delta x_i \\ &\approx n \cdot \Delta x \end{aligned} \quad (5.1)$$

$$\begin{aligned} \int_{d_0}^{d_1} w(x) dx &\approx \sum_{i=1}^n w(x_i) \cdot \Delta x_i \\ &\approx \Delta x \cdot \sum_{i=1}^n w(x_i) \end{aligned} \quad (5.2)$$

$$\begin{aligned}
\int_{d_0}^{d_1} r_L^{t,t+1}(x) dx &\approx \sum_{i=1}^n r_L^{t,t+1}(x_i) \cdot \Delta x_i \\
&\approx \Delta x \cdot \sum_{i=1}^n r_L^{t,t+1}(x_i)
\end{aligned} \tag{5.3}$$

$$\begin{aligned}
\int_{d_0}^{d_1} w(x) \cdot r_L^{t,t+1}(x) dx &\approx \sum_{i=1}^n w(x_i) \cdot r_L^{t,t+1}(x_i) \cdot \Delta x_i \\
&\approx \Delta x \cdot \sum_{i=1}^n w(x_i) \cdot r_L^{t,t+1}(x_i).
\end{aligned} \tag{5.4}$$

Substituting equations (5.1), (5.2), (5.3) and (5.4) in equation (4.4), we obtain;

$$R_L \approx \frac{\sum_{i=1}^n w(x_i) \cdot r_L^{t,t+1}(x_i)}{\sum_{i=1}^n w(x_i)} \cdot \frac{n}{\sum_{i=1}^n r_L^{t,t+1}(x_i)} - 1.0 \tag{5.5}$$

Equation (5.5) is coincidentally identical with the formulation of the conventional ROXY index except for the scaling factor 10,000.

This coincidental identicalness would heuristically provide us with the suggestion on why the conventional formulation of the ROXY index has the drawback that the index has its dependency on the pattern of the spatial distribution of subareas. That is, the reason for that drawback is that the spatial distribution or the spatial density of subareas is implicitly assumed to be uniform. The introduction of this implicit assumption in the formulation of the conventional ROXY index would correspond to the step made at the process of the derivation of the second line from the first in all equations (5.1), (5.2), (5.3) and (5.4) in which Δx_i is replaced by constant Δx .

5.2 Approximation Means Leading to New Formulations of ROXY Index

In order to calculate the value of the ROXY index as close to the idealistic ROXY index as possible, we conduct analytical calculations for two of the above four integrals. For the

other two integrals as to the growth ratio, we first interpolate the growth ratio by the spline function¹⁾, and then we conduct analytical calculations for these two integrals.

5.2.1 New Formulation of ROXY Index for One-dimensional Continuous-linear Region

The two analytical integrals have been already performed in equation (4.24) which appears as follows;

$$R_{LN} = \left\{ \frac{2 \int_{d_0}^{d_1} x r_L^{t,t+1}(x) dx}{(d_1 + d_0) \cdot \int_{d_0}^{d_1} r_L^{t,t+1}(x) dx} - 1.0 \right\} \times \frac{d_1 + d_0}{d_1 - d_0} \times 10^4 \quad (4.24)$$

Two integrals in the above expression have the growth ratio $r_L^{t,t+1}(x)$ whose value can be obtained discretely over the distance x . We interpolate the discrete growth ratio through the following third-order spline function;

$$r_{LS}(x) = a_0 + a_1 x + \sum_{i=1}^n c_i (x - x_i)_+^3 \quad (i=1, 2, \dots, n) \quad (5.6)$$

Assuming that the nearest distance d_0 is equal to zero, the two integrals respectively turn out to be;

$$\begin{cases} \int_{d_0}^{d_1} f(x) dx = \frac{1}{2} a (x_n^2 - x_1^2) + b(x_n - x_1) + \frac{1}{4} \sum_{i=1}^n c_i (x_n - x_i)^4 \\ \int_{d_0}^{d_1} x f(x) dx = \frac{1}{3} a (x_n^3 - x_1^3) + \frac{1}{2} b (x_n^2 - x_1^2) + \sum_{i=1}^n c_i \left\{ \frac{1}{5} (x_n - x_i)^5 + \frac{1}{4} (x_n - x_i)^4 \right\} \end{cases} \quad (5.7)$$

It is clear that the above formulation of the ROXY index has no dependency on the spatial distribution pattern of subareas, and that, if we normalize the value of the above formulation, the minimum value would be equal to $-10,000$ and the maximum equal to $+10,000$.

5.2.2 New Formulation of ROXY Index for Two-dimensional Fan-shaped Region

Taking the similar steps into our considerations as those for the one-dimensional continuous-linear region, the approximated formulation of the ROXY index for the two-dimensional fan-shaped region can be obtained. First we know that the two analytical integrals have been already performed in equation (4.36) which appears as follows;

$$R_{LN} = \left\{ \frac{2}{(d_1^2 + d_0^2)} \cdot \frac{\int_{d_0}^{d_1} r_{r,t,t+1}(x) \cdot x^3 dx}{\int_{d_0}^{d_1} r_{r,t,t+1}(x) \cdot x dx} - 1.0 \right\} \times \frac{d_1^2 + d_0^2}{d_1^2 - d_0^2} \times 10^4 \quad (4.36)$$

Two integrals in the above expression have the growth ratio $r_{r,t,t+1}(x)$ whose value can be obtained discretely over the distance x . We interpolate the discrete growth ratio through the following third-order spline function.

$$r_{FS}(x) = a_0 + a_1 x + \sum_{i=1}^n c_i (x - x_i)_+^3 \quad (5.8)$$

Assuming that the nearest distance d_0 is equal to zero, the two integrals turn out to be as follows;

$$\begin{cases} \int_{d_0}^{d_1} f(x) dx = \frac{1}{3} a(x_n^3 - x_1^3) + \frac{1}{2} b(x_n^2 - x_1^2) + \sum_{i=1}^n c_i \left\{ \frac{1}{5} (x_n - x_i)^5 + \frac{1}{4} (x_n - x_i)^4 \right\} \\ \int_{d_0}^{d_1} f(x) x^3 dx = \frac{1}{5} a(x_n^5 - x_1^5) + \frac{1}{4} b(x_n^4 - x_1^4) + \\ \sum_{i=1}^n c_i \left\{ \frac{1}{7} (x_n - x_i)^7 + \frac{1}{2} x_1 (x_n - x_i)^6 + \frac{3}{5} x_1^2 (x_n - x_i)^5 + \frac{1}{4} x_1^3 (x_n - x_i)^4 \right\} \end{cases} \quad (5.9)$$

6 Comparative Analysis on Values of ROXY Indices for Three Types of Formulations: Discrete-liner Region, Continuous-liner Region, and Fan-shaped Region

For our investigation to compare the values of three types of the ROXY indices, we pick up the region consisting of localities situated along the Takasaki Line which is one of the busiest commuting lines in the Tokyo Functional Urban Region (FUR)¹²⁾. The localities which belongs to the Takasaki-line region are selected among the localities in the 1990-version of the Tokyo FUR which is delineated in Kawashima *et al.* (1993). We set up two types of regions to examine the dependency of the ROXY index on the spatial distribution of subareas. In the first type, called type-a, the central part of Tokyo (*Tokyo-Tokubetsu-Kubu*) is aggregated into one subarea. The geophysical boundary for the type-a is shown in Figure 24. In the second type, called type-s, the central part of Tokyo is disaggregated into 23 subareas, among which three subareas are eligible to belong to the

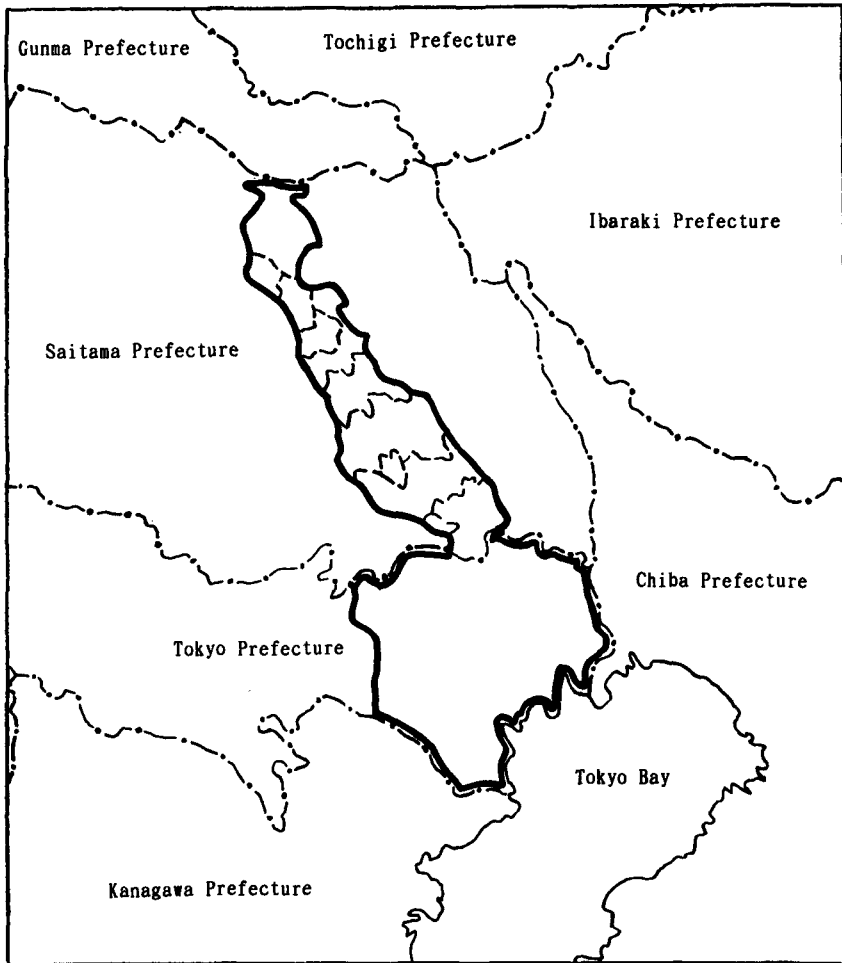

**Figure 24 Geographical Boundary for Type-a (i.e., Aggregated Case)
of Takasaki-line Region**

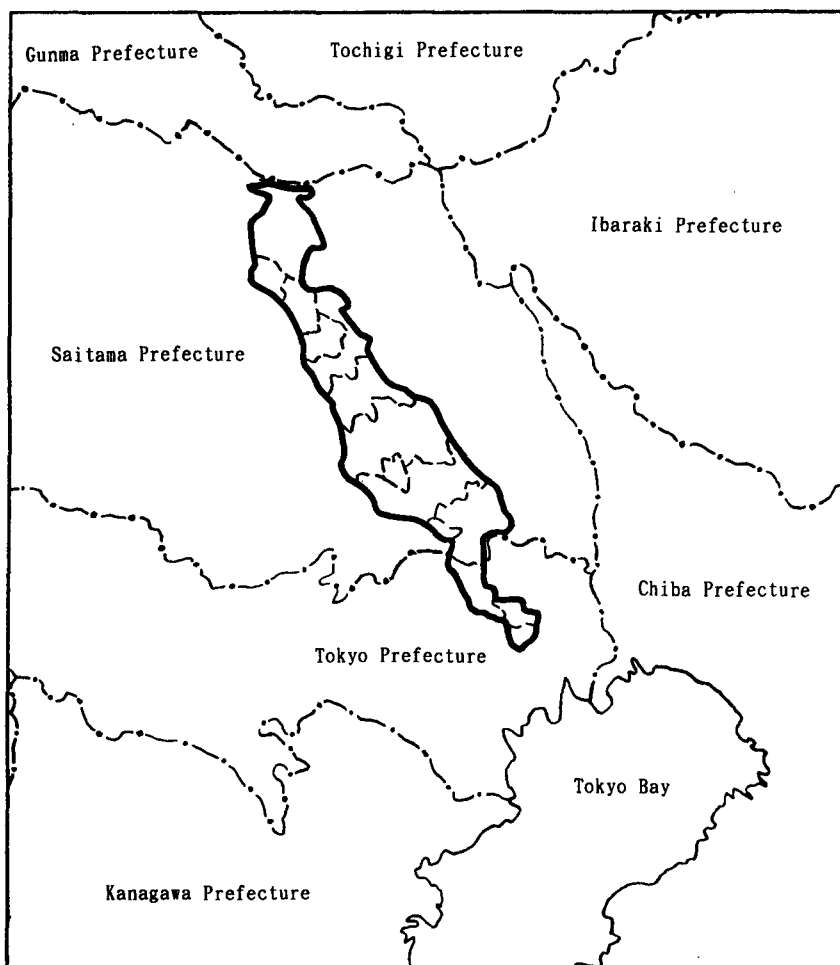

Figure 25 Geographical Boundary for Type-s (i.e., Disaggregated Case) of Takasaki-line Region

Takasaki-line region. The geophysical boundary of the type-s is shown Figure 25. Tables A-1 through A-4 in the Appendix furnish names, code numbers, distances, populations, five-year growth rates of population and annual growth ratios of population for localities in the Takasaki-line region.

6.1 Values of Conventional ROXY Index for Discrete-linear Region

Table 21 shows the values and their marginal changes of the conventional formulation of the ROXY index calculated based on Tables A-1 through A-4. From this table, we can draw Figure 26 diagrammatically showing the change in the value of the ROXY index.

Comparing the values for the type-a with the values for the type-s, it is obvious that the values of the conventional ROXY index is more or less effected by the disaggregation of *Tokyo Tokubetsu-Kubu*, and that the values obtained for the type-s are greater than the values obtained for the type-a.

6.2 Values of New Formulation of ROXY Index

6.2.1 Values of New Formulation of ROXY Index for One-dimensional Continuous-linear Region

Before the calculation of the values of the new formulation of the ROXY index, the growth ratio must be interporated by a spline function. Figure 27 shows the examples for the interporated growth ratio. In this figure, the cross-marks represent subareas and their respective annual growth ratios. The two curves for the interporated growth ratio are almost identical in the range of the distance greater than 15 km, while they are different in the range of the distance less than 15 km.

Table 22 furnishes the values and their marginal changes obtained by the approximate formulation of the ROXY index for the one-dimensional continuous-linear region. From this table, we can draw Figure 28. It can be seen that the values of the ROXY indices for the type-a and type-s are almost the same and that they are not effected by the disaggregation of *Tokyo-Tokubetsu-Kubu*, though they are slightly effected by the difference of the interporated growth ratios in the range of the distance less than 15 km.

6.2.2 Values of New Formulation of ROXY Index for Two-dimensional Fan-shaped Region

In the calculation of the values of the new formulation of the ROXY index for the two-dimensional fan-shaped region, we employ the same interporated growth ratio as we used for the one-dimensional continuous-linear region.

Table 23 furnishes the values and their marginal changes obtained by the appnxiimate formulation of the ROXY index for the two-dimensional fan-shaped region. From this table, we can draw Figure 29. It can be seen that the values of the ROXY indices for the type-a and type-s are almost the same, and that the values for the two-dimensional fan-shaped

Table 21 Values and Their Marginal Changes of Conventional Formulation of ROXY Index

Items		1960-65	1965-70	1970-75	1975-80	1980-85	1985-90
Type-a	Value	-29.49	35.23	41.46	46.77	28.65	18.07
	Marginal change	64.73	35.47	5.77	-6.40	-14.35	-10.58
Type-s	Value	36.20	122.95	106.86	90.51	56.55	50.25
	Marginal change	86.75	35.33	-16.22	-25.15	-20.13	-6.30

Table 22 Values and Their Marginal Changes of the New Formulation of ROXY Index for Continuous-linear Region

Items		1960-65	1965-70	1970-75	1975-80	1980-85	1985-90
Type-a	Value	59.61	132.86	114.94	105.42	52.57	65.63
	Marginal change	73.26	27.67	-13.72	-31.18	-19.90	13.06
Type-s	Value	58.34	136.94	105.23	93.12	55.65	67.29
	Marginal change	78.61	23.45	-21.91	-24.79	-12.92	11.63

Table 23 Values and Their Marginal Changes of New Formulation of ROXY Index for Two-dimensional Fan-shaped Region

Items		1960-65	1965-70	1970-75	1975-80	1980-85	1985-90
Type-a	Value	-54.40	-47.10	-8.41	47.84	21.21	19.75
	Marginal change	7.29	22.99	47.47	14.81	-14.04	-1.46
Type-s	Value	-50.37	-40.61	-5.11	52.87	25.87	22.39
	Marginal change	9.76	22.63	46.74	15.49	-15.24	-3.48

Mathematical Characteristics of ROXY Index (II): Periods of Intra-metropolitan Spatial-cycle Paths and Theoretically-ideal Formulations of ROXY Index (Hiraoka, Kawashima)

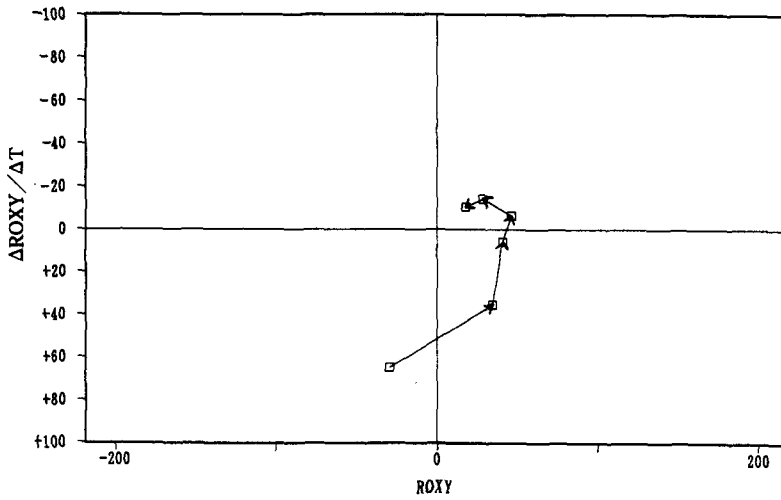

(a) For aggregated case

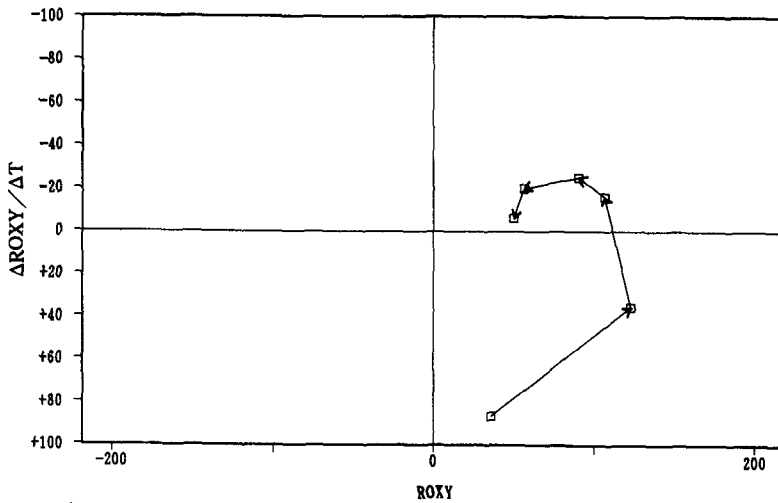

(b) For disaggregated case

Figure 26 Conventional Formulation of ROXY Index: Values and Their Marginal Changes (Aggregated and Disaggregated Cases) for Takasaki-line Region:

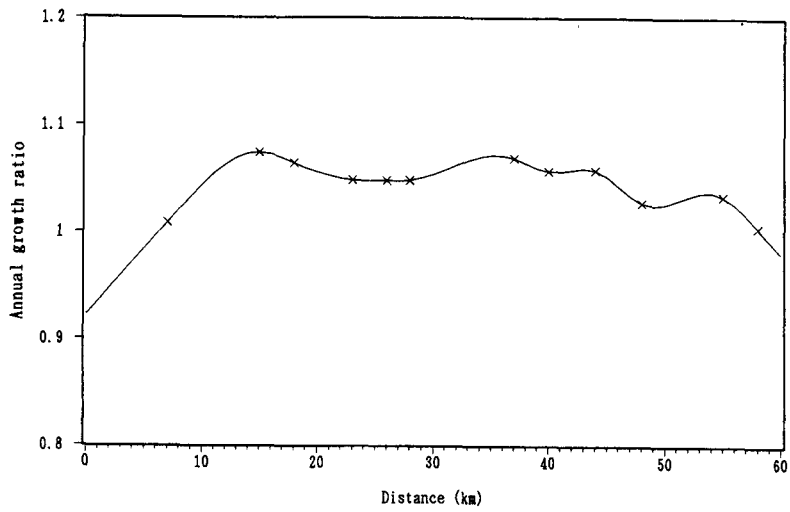

(a) For aggregated case

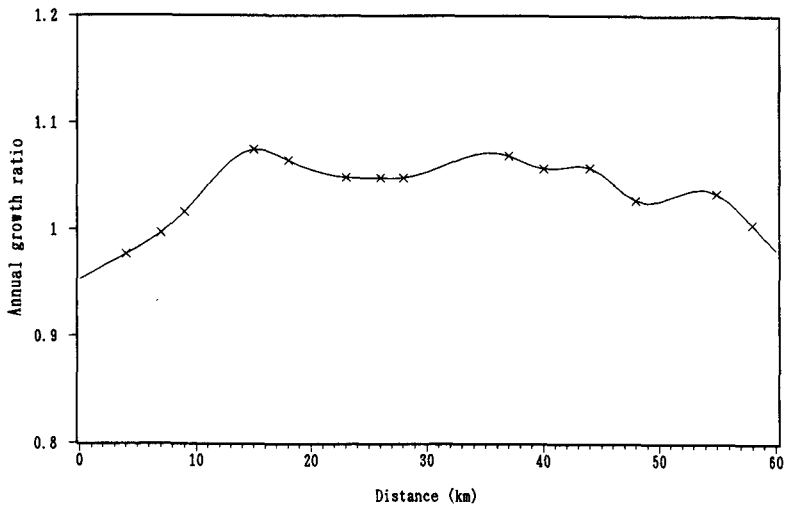

(b) For disaggregated case

Figure 27 Examples of Interporated Growth Ratio: Annual Growth Ratio of Population for 1960-65 Period

Mathematical Characteristics of ROXY Index (II): Periods of Intra-metropolitan Spatial-cycle Paths and Theoretically-ideal Formulations of ROXY Index (Hiraoka, Kawashima)

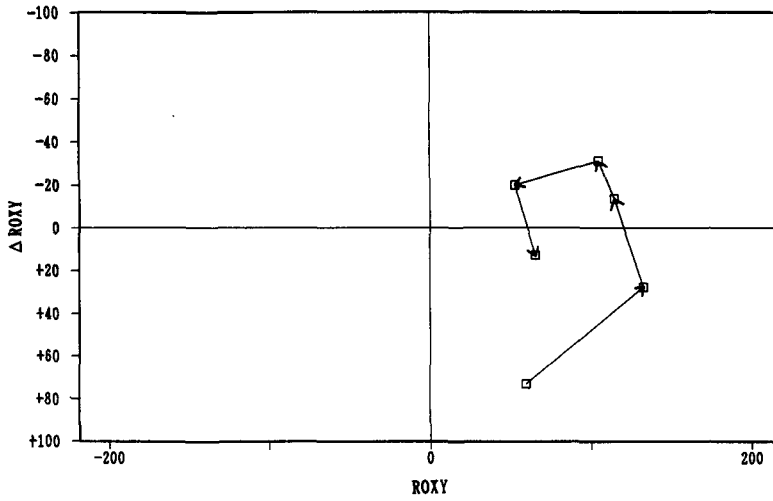

(a) For aggregated case

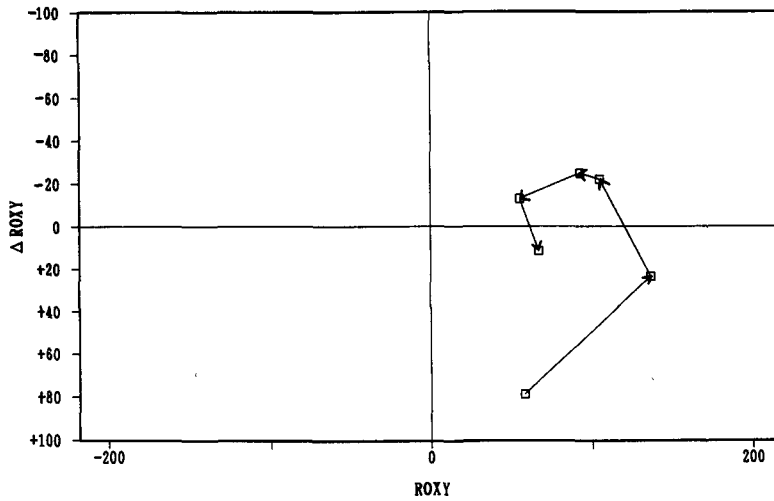

(b) For disaggregated case

Figure 28 New Formulation of ROXY Index in terms of Continuous-linear Region: Values and Their Marginal Changes (Aggregated and Disaggregated cases) for Takasaki-line Region

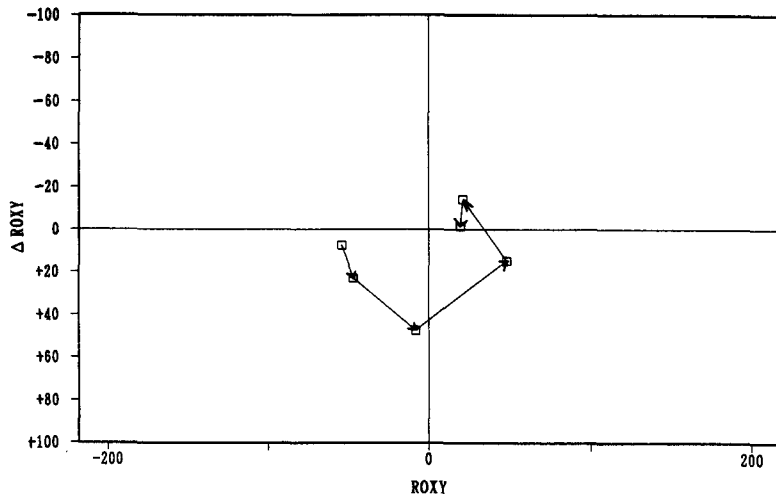

(a) For aggregated case

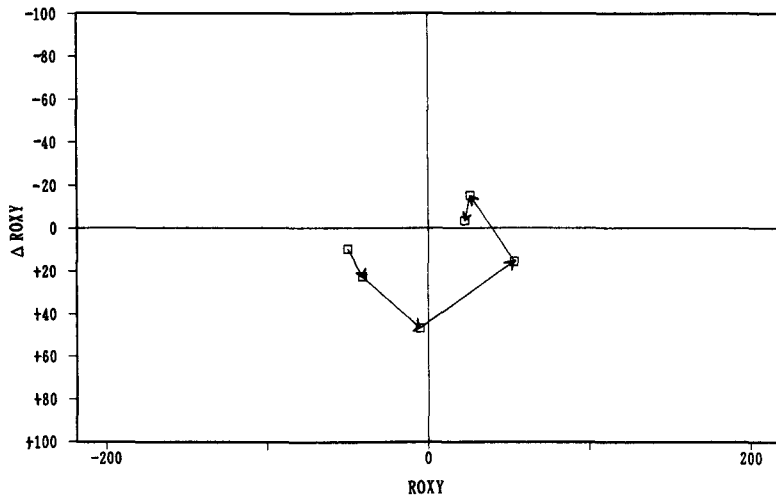

(b) For disaggregated case

Figure 29 New Formulation of ROXY Index in terms of Two-dimensional Fan-shaped Region: Values and Their Marginal Changes (Aggregated and Disaggregated Cases) for Takasaki-line Region

region are smaller than the values for the one-dimensional continuous-linear region, since the boundary between the core and ring for the fan-shaped region tends to be delineated outer than that for the continuous-linear region. It is to be noted that, by this reason, the suburbanization for the fan-shaped region is retarded to some extent as compared with the suburbanization for the continuous-linear region.

6.3 Comparison of Three Types of Formulations of ROXY Index

The above results in this section show that the values of the conventional formulation of the ROXY index are effected by the degrees and ways of spatial disaggregation of the central part of Tokyo, and that the values of the two types of the approximation formulations for the theoretically-ideal ROXY index seem to be only slightly affected, if any.

7 Lessons and Suggestions from Investigations in Part II

The ROXY index has been playing important roles in the analysis on the stage of intra- and inter-metropolitan spatial redistribution processes. At the same time, over the last several years, analyses using the ROXY index have made a great progress in which a great deal of the efforts has been made on the application of the ROXY index to the measurement of urbanization or suburbanization of metropolitan areas. What seems to be lacking, however, is the profound investigation of the formulation of the ROXY index itself.

To provide a starting-point to the investigation of the formulation of the ROXY index, we focused our attention on a type of the ROXY index of which weighing factor is the function of the distance to the central business district (CBD) of the central city in a metropolitan area from each of subareas, since this type of the ROXY index seems to be employed most frequently among various types of ROXY-index analyses.

We began with the observation of the conventional formulation of the ROXY index. It shows that the conventional formulation has the drawback that the value of the ROXY index has its dependency on the spatial distribution pattern of subareas. An important suggestion then arises: (i) In the comparative analysis of metropolitan areas, it would be inappropriate to say that two metropolises are on the same stage of urbanization even though their indices have the same value, and (ii) in the intra-metropolitan time-series analysis the value of the conventional ROXY index has the asymmetry concerning its maximum and minimum values.

Our normalized theoretically-ideal ROXY index has no dependency on the spatial distribution pattern of subareas, and its value is symmetric as to its maximum and minimum. Since the normalized theoretically-ideal ROXY index itself cannot be applied to actual data that are discretely distributed over the distance, we have developed, in the present paper, approximation method which would help us calculate the value close to the value of the ideal ROXY index. Applying the approximation method to the Takasaki-line

region of the Tokyo metropolitan area for the period 1960–90, we have learned that the values obtained through the approximation method are only slightly affected by the spatial distribution pattern of subareas.

We have also learned, through our investigation, that the position of the boundary dividing the “core” and “ring” is dependent on the form of the weighing function.

Conclusion : Research Agenda

Based on our investigations, the possibly suggested research agenda for the future ROXY-index studies would be as follows;

- (1) conduct of simulation studies in search of typical scenarios that might make the general implications of the values of the ROXY index rather seriously misleading, and
- (2) conduct of applied ROXY-index studies in search of other useful *combinations of weighing factors and variables* (in which we are interested in obtaining a better insight into their spatial/hierarchical/networkwise redistribution processes) than those combinations which have already been investigated.

The former studies would help us understand potentially well-hidden structural limitations of the ROXY-index approach and consequently reinforce its theoretical weak points. The latter studies would hopefully make a contribution to the possible expansion of the scope of the ROXY-index method as an analytical instrument for empirical researches of the dynamic phenomena in the time-space dimension in a broader sense.

Notes

- 1) For the localities constituting each railway-line region, see Kawashima and Hiraoka (1993a).
- 2) For the definition of reversed distance, see Kawashima and Hiraoka (1993b).
- 3) The year t on the horizontal scales in Panels (a), (b), and (c) of Figures 1 and 2, indicates the change between the previous year $t-1$ and the present year t . For example, the year 1964 on the horizontal scale denotes the change between 1963 and 1964.
- 4) Another possible way to smoothen the change in the value of the ROXY index would be to employ, for example, three-year-averaged population, $P_3(t)$, or five-year-averaged population, $P_5(t)$, with the following definitions:

$$P_3(t) = (P(t-1) + P(t) + P(t+1)) / 3$$

$$P_5(t) = (P(t-2) + P(t-1) + P(t) + P(t+1) + P(t+2)) / 5$$

where $P(t)$ is the population of year t .

Table N-1 shows the value of the ROXY index by three-year-averaged population for five railway-line regions in disaggregated case, and Table N-2 in aggregated case. Table N-3 shows the value of the ROXY index by three-year-averaged population for five railway-line regions in disaggregated case, and Table N-4 in aggregated case. Panels (b) and (c) in Figure N-1 show values of the ROXY index by three-year-averaged population and five-year-averaged population for five railway-line regions in aggregated case, and Panels (b) and (c) in Figure N-2 show values in disaggregated case. Panels (b) and (c) of Figure N-3 through N-12 show the relationship of the three- and five-year-averaged ROXY index respectively with the marginal changes in their values for each railway-line region.

- 5) In Kawashima (1986a, 1986b, 1986c) is used the CBD distance as weighing factor, and in Kawashima (1987) and Kawashima and Hiraoka (1993a) is used the reversed distance as weighing factor.
- 6) This functional relation is obtained through the following calculations. First, we define the ROXY index, R_d , whose weighing factor is the CBD distance and the ROXY index, R_l , whose weighing factor is the reversed distance as follows;

$$R_d \equiv \left\{ \frac{\sum_{i=1}^n d_i \cdot r_i^{t,t+1}}{\sum_{i=1}^n d_i} \cdot \frac{n}{\sum_{i=1}^n r_i^{t,t+1}} - 1.0 \right\} \times 10^4$$

$$R_l \equiv \left\{ \frac{\sum_{i=1}^n l_i \cdot r_i^{t,t+1}}{\sum_{i=1}^n l_i} \cdot \frac{n}{\sum_{i=1}^n r_i^{t,t+1}} - 1.0 \right\} \times 10^4$$

Then we have,

$$R_l \times 10^{-4} = \frac{\sum_{i=1}^n (d_{min} + d_{max} - d_i) \cdot r_i^{t,t+1}}{\sum_{i=1}^n l_i} \cdot \frac{n}{\sum_{i=1}^n r_i^{t,t+1}} - 1.0$$

$$= \frac{\sum_{i=1}^n (d_{min} + d_{max}) \cdot r_i^{t,t+1} - \sum_{i=1}^n d_i \cdot r_i^{t,t+1}}{\sum_{i=1}^n l_i} \cdot \frac{n}{\sum_{i=1}^n r_i^{t,t+1}} - 1.0$$

Table N-1 Values of ROXY Index by 3-year-averaged Population in Aggregated Case

Region	1963-64	1964-65	1965-66	1966-67	1967-68	1968-69	1969-70	1970-71	1971-72	1972-73	1973-74	1974-75	1975-76	1976-77
Chuo-line region	3.169	1.512	-2.326	1.687	2.554	-2.797	-12.045	-18.719	-23.375	-26.591	-29.959	-29.781	-27.579	-24.018
Takasaki-line region	16.630	15.636	2.245	-18.100	-31.887	-40.047	-42.421	-49.053	-47.901	-45.868	-39.097	-36.743	-37.919	-41.905
Joban-line region	67.201	83.858	60.878	40.249	31.256	16.341	4.554	-9.274	-20.044	-33.115	-40.317	-45.390	-41.535	-50.971
Tokaido-line region	-103.924	-154.599	-156.959	-106.422	-88.314	-79.835	-75.711	-69.015	-78.466	-81.050	-83.663	-75.802	-68.295	-65.407
Sobu-line region	44.494	58.174	45.652	72.942	33.473	18.592	-28.388	-16.311	-29.550	-45.139	-67.298	-73.968	-74.968	-71.514

1977-78	1978-79	1979-80	1980-81	1981-82	1982-83	1983-84	1984-85	1985-86	1986-87	1987-88	1988-89	1989-90	1990-91	1991-92
-24.882	-24.902	-34.938	-35.979	-31.876	-13.532	-6.541	-2.249	-7.079	-11.162	-18.216	-21.983	-22.165	-19.980	-12.517
-46.900	-47.860	-49.202	-52.504	-39.960	-30.268	-16.699	-18.839	-14.837	-15.989	-18.597	-23.538	-24.453	-20.585	-12.092
-64.657	-87.446	-89.454	-89.438	-71.357	-58.542	-36.357	-25.289	-27.800	-27.627	-43.600	-44.953	-53.897	-45.103	-29.255
-60.658	-56.961	-47.408	-42.602	-32.572	-20.884	-11.531	-7.667	-10.138	-16.902	-20.942	-22.883	-17.205	-16.929	-8.733
-84.669	-102.927	-100.505	-108.861	-90.593	-81.265	-52.236	-37.698	-35.213	-46.543	-67.890	-78.364	-77.749	-69.366	-42.649

Table N-2 Values of ROXY Index by 3-year-averaged Population in Disaggregated Case

Region	1963-64	1964-65	1965-66	1966-67	1967-68	1968-69	1969-70	1970-71	1971-72	1972-73	1973-74	1974-75	1975-76	1976-77
Chuo-line region	-69.108	-99.819	-89.878	-79.530	-64.686	-68.342	-68.561	-77.209	-78.407	-76.667	-73.098	-68.011	-62.134	-60.290
Takasaki-line region	-31.512	-52.378	-67.761	-83.258	-100.279	-111.827	111.887	115.518	108.335	101.162	-88.340	-78.150	-76.122	-76.058
Joban-line region	-0.119	-5.407	-26.772	-42.205	-59.623	-92.928	117.720	130.938	131.153	137.695	142.407	140.358	126.973	130.883
Tokaido-line region	-159.204	-211.472	-199.957	-142.505	-129.252	-122.827	118.716	111.809	114.175	121.006	126.853	116.466	101.144	-92.866
Sobu-line region	-48.045	-64.201	-66.493	-56.855	-90.386	-112.981	132.532	124.080	129.188	149.013	165.967	163.204	150.713	140.373

1977-78	1978-79	1979-80	1980-81	1981-82	1982-83	1983-84	1984-85	1985-86	1986-87	1987-88	1988-89	1989-90	1990-91	1991-92
-58.530	-52.993	-52.003	-48.280	-42.292	-33.006	-24.360	-28.012	-34.367	-48.631	-57.156	-62.347	-60.466	-56.911	-36.582
-80.464	-79.416	-79.657	-80.876	-66.005	-51.086	-35.424	-36.957	-37.652	-42.231	-46.702	-50.346	-48.594	-43.200	-26.727
-136.192	-151.858	-140.842	-134.537	-111.294	-94.560	-69.325	-54.515	-51.377	-56.789	-69.672	-72.525	-70.612	-59.561	-38.229
-87.533	-73.098	-57.671	-47.013	-40.706	-39.227	-33.269	-37.391	-45.279	-63.990	-69.303	-68.818	-58.903	-57.500	-37.554
-145.879	-152.733	-141.834	-137.585	-113.685	-99.677	-69.995	-59.347	-59.702	-78.937	-100.313	-107.250	-100.058	-89.131	-56.630

Table N-3 Values of ROXY Index by 5-year-averaged Population in Aggregated Case

Region	1963-64	1964-65	1965-66	1966-67	1967-68	1968-69	1969-70	1970-71	1971-72	1972-73	1973-74	1974-75	1975-76	1976-77
Chuo-line region	0.791	2.553	3.251	-1.151	-1.542	-5.448	-11.248	-16.570	-22.369	-27.114	-27.271	-27.872	-27.520	-26.136
Takasaki-line region	9.811	5.198	-2.416	-14.998	-27.737	-35.950	-45.549	-45.010	-44.524	-43.799	-40.492	-38.615	-40.833	-41.685
Joban-line region	53.725	60.539	61.397	46.572	29.387	14.485	3.803	-7.020	-23.487	-30.199	-36.932	-41.878	-48.452	-56.295
Tokaido-line region	-98.370	-110.247	-120.272	-128.124	-93.801	-78.167	-77.986	-77.489	-74.515	-80.433	-77.609	-73.824	-72.453	-65.318
Sobu-line region	37.032	42.607	69.202	40.396	27.140	14.458	1.980	-31.483	-31.740	-49.691	-60.106	-67.342	-73.526	-82.341

1977-78	1978-79	1979-80	1980-81	1981-82	1982-83	1983-84	1984-85	1985-86	1986-87	1987-88	1988-89	1989-90	1990-91	1991-92
-24.754	-30.629	-31.322	-29.790	-23.583	-19.626	-10.131	-6.630	-7.537	-12.995	-15.916	-19.503	-20.743	-16.653	-11.890
-44.274	-48.564	-50.740	-43.029	-37.964	-30.963	-24.843	-16.115	-17.040	-17.997	-20.147	-20.408	-21.279	-17.583	-12.260
-71.407	-76.079	-84.341	-80.841	-70.015	-52.865	-42.523	-34.316	-27.639	-34.490	-39.734	-45.097	-44.634	-39.927	-26.673
-58.148	-55.408	-49.882	-38.554	-31.453	-22.584	-14.720	-12.128	-13.379	-14.864	-18.922	-18.986	-18.935	-13.995	-10.128
-89.577	-91.003	-103.478	-98.410	-86.841	-69.926	-59.320	-45.371	-45.636	-53.348	-62.145	-69.658	-72.782	-58.095	-40.282

Table N-4 Values of ROXY Index by 5-year-averaged Population in Disaggregated Case

Region	1963-64	1964-65	1965-66	1966-67	1967-68	1968-69	1969-70	1970-71	1971-72	1972-73	1973-74	1974-75	1975-76	1976-77
Chuo-line region	-61.998	-72.526	-87.251	-79.741	-71.395	-70.077	-73.504	-71.151	-76.488	-75.599	-71.030	-68.273	-65.035	-59.809
Takasaki-line region	-32.392	-50.253	-69.650	-84.557	-96.099	-103.665	-113.309	-110.668	-104.749	-97.828	-89.236	-82.064	-79.382	-77.445
Joban-line region	-2.936	-11.657	-25.444	-43.352	-68.220	-93.893	-108.192	-120.951	-137.497	-136.356	-135.186	-134.978	-136.553	-134.487
Tokaido-line region	-133.228	-155.388	-172.528	-168.465	-133.756	-121.855	-118.404	-116.295	-116.579	-116.649	-117.067	-113.335	-107.538	-93.629
Sobu-line region	-39.201	-52.691	-62.869	-81.528	-92.494	-103.803	-114.659	-134.198	-138.637	-147.456	-154.082	-155.561	-153.225	-150.453

1977-78	1978-79	1979-80	1980-81	1981-82	1982-83	1983-84	1984-85	1985-86	1986-87	1987-88	1988-89	1989-90	1990-91	1991-92
-56.011	-55.518	-51.793	-45.594	-39.920	-33.942	-31.107	-31.811	-37.830	-45.284	-54.372	-57.560	-59.395	-47.551	-34.449
-77.130	-80.705	-80.656	-71.036	-62.505	-53.149	-45.435	-37.311	-39.352	-42.973	-46.143	-46.282	-46.107	-36.608	-25.852
-141.733	-137.731	-138.335	-127.706	-110.863	-88.332	-76.100	-62.129	-56.652	-62.080	-64.619	-66.542	-66.417	-52.752	-35.337
-81.416	-72.352	-61.057	-50.203	-43.303	-37.080	-37.937	-42.226	-50.976	-55.745	-63.351	-64.101	-63.698	-47.870	-34.992
-148.088	-141.611	-143.129	-129.997	-112.205	-90.605	-79.273	-68.026	-71.723	-81.463	-91.323	-96.189	-98.346	-76.631	-52.549

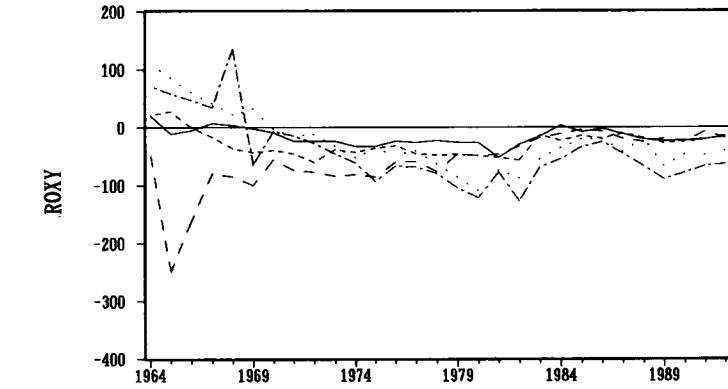

(a) ROXY index by annual population data (1963-92)

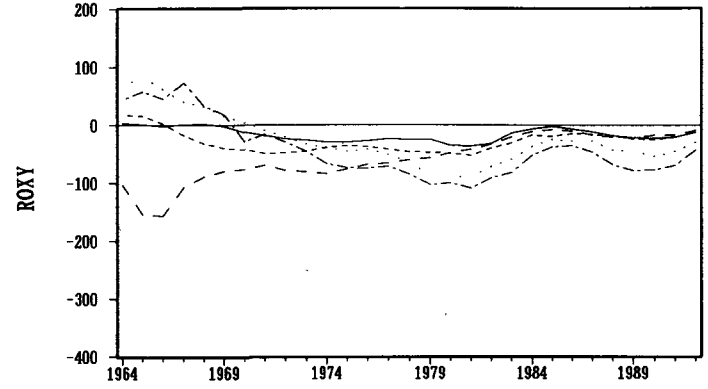

(b) ROXY index by three-year moving-average of population (1963-92)

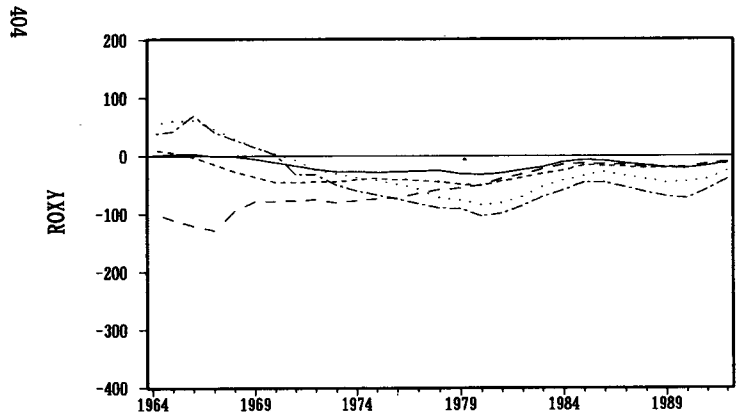

(c) ROXY index by five-year moving-average of population (1963-92)

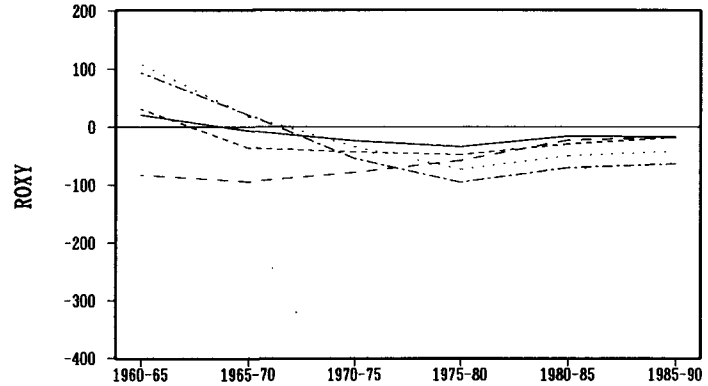

(d) ROXY index by National Population Census data (1960-90)

Chuo-line:—— Takasaki-line:----- Joban-line:..... Tokaido-line:---- Sobu-line:-----

Figure N-1 Four Types of ROXY Indices by Use of Moving-average of Population for Five Railway-line Regions: Aggregated Case

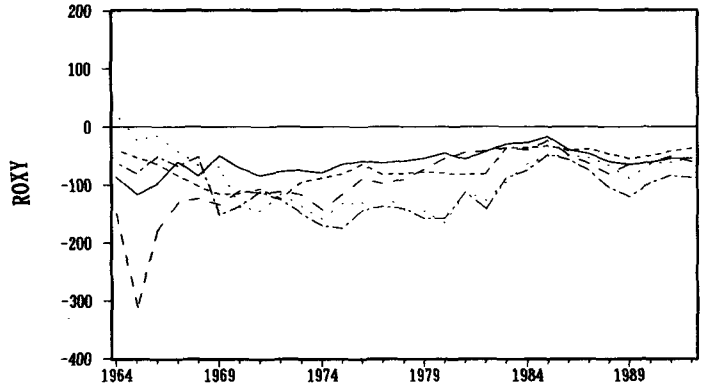

(a) ROXY index by annual population data (1963-92)

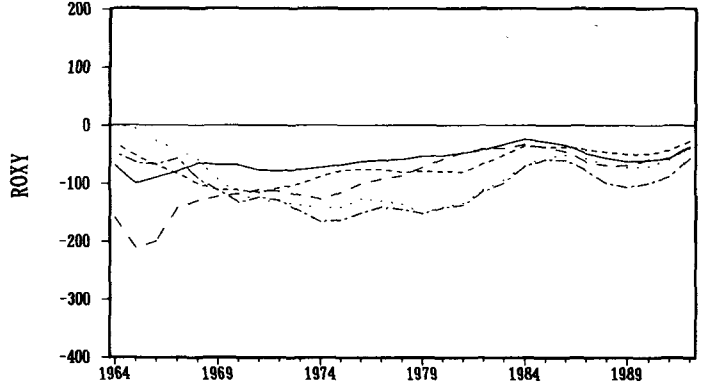

(b) ROXY index by three-year moving-average of population (1963-92)

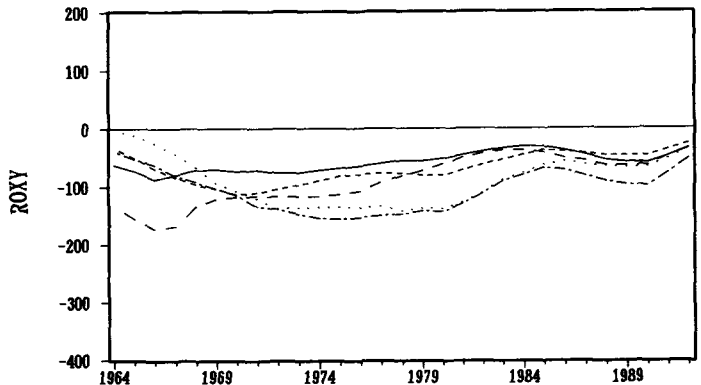

(c) ROXY index by five-year moving-average of population (1963-92)

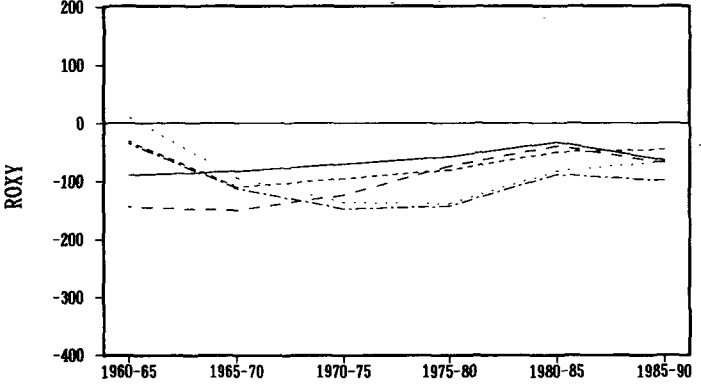

(d) ROXY index by National Population Census data (1960-90)

Chuo-line:—— Takasaki-line:----- Joban-line:..... Tokaido-line:----- Sobu-line:-----

Figure N-2 Four Types of ROXY Indices by Use of Moving-average of Population for Five Railway-line Regions: Disaggregated Case

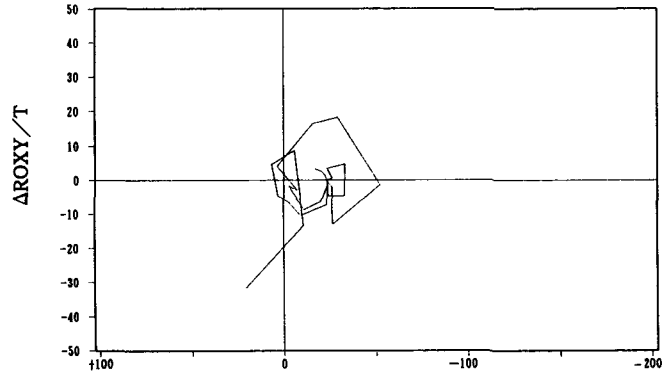

(a) ROXY index by annual population data (1963-92)

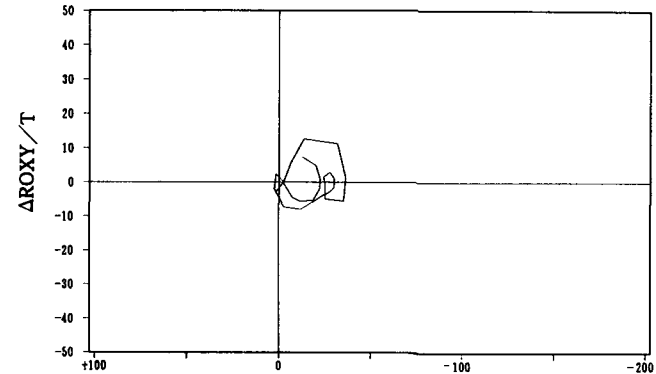

(b) ROXY index by three-year moving-average of population (1963-92)

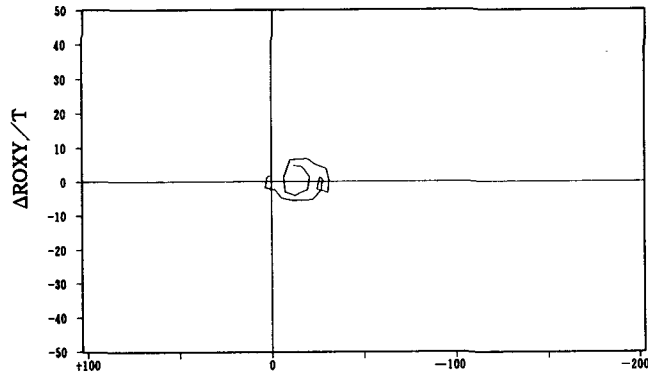

(c) ROXY index by five-year moving-average of population (1963-92)

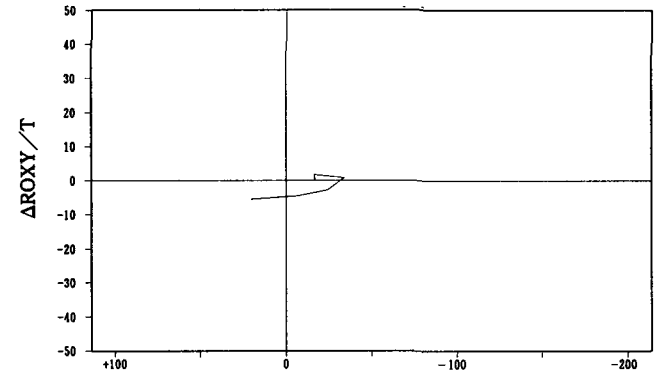

(d) ROXY index by National Population Census data (1960-90)

406

Figure N-3 Four Types of ROXY Indices and Their Marginal Values by Use of Moving-average of Population for Chuo-line Region: Aggregated Case

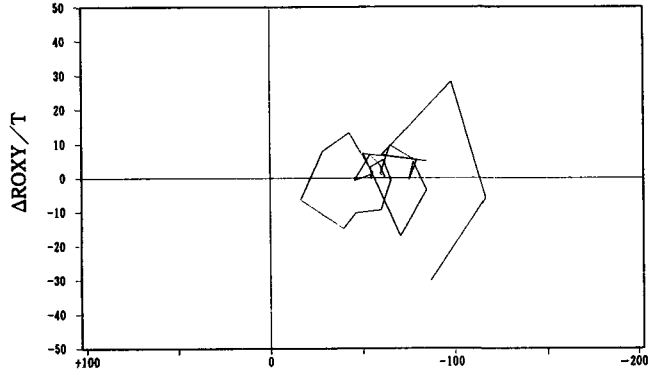

(a) ROXY index by annual population data (1963-92)

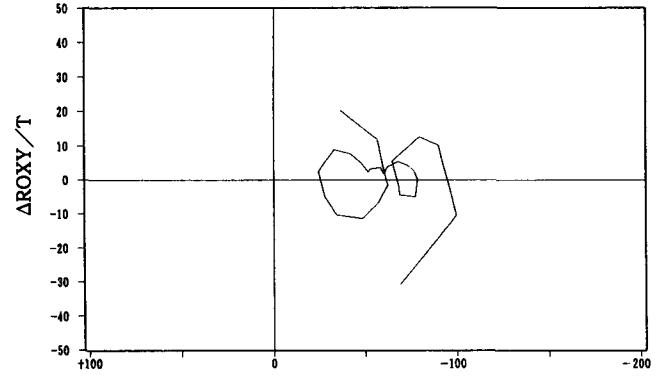

(b) ROXY index by three-year moving-average of population (1963-92)

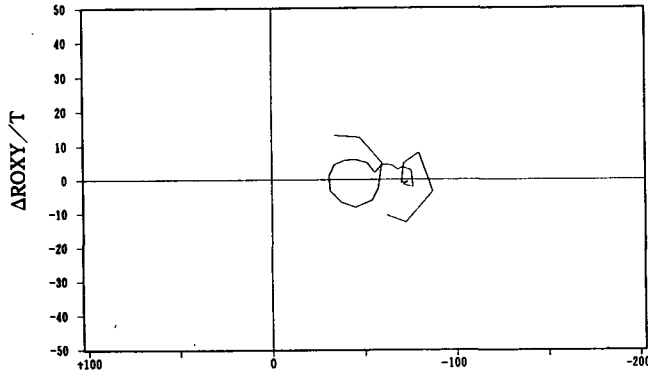

(c) ROXY index by five-year moving-average of population (1963-92)

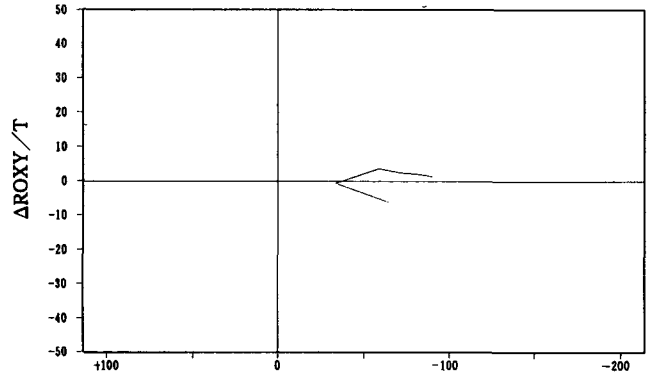

(d) ROXY index by National Population Census data (1960-90)

Figure N-4 Four Types of ROXY Indices and Their Marginal Values by Use of Moving-average of Population for Chuo-line Region: Disaggregated Case

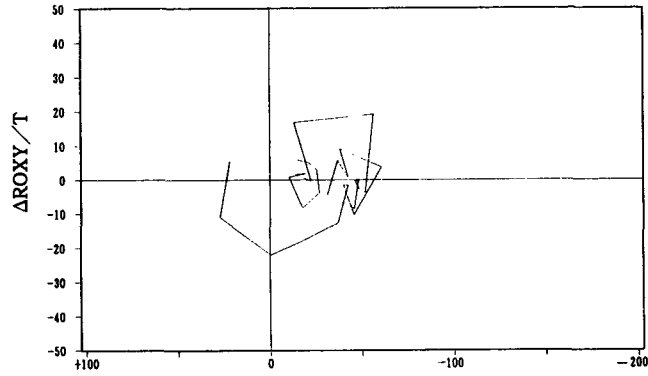

(a) ROXY index by annual population data (1963-92)

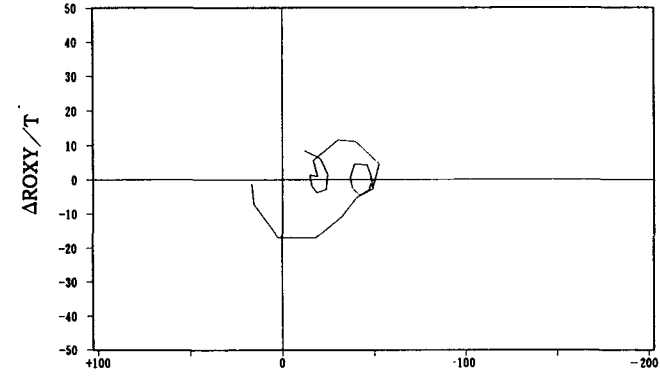

(b) ROXY index by three-year moving-average of population (1963-92)

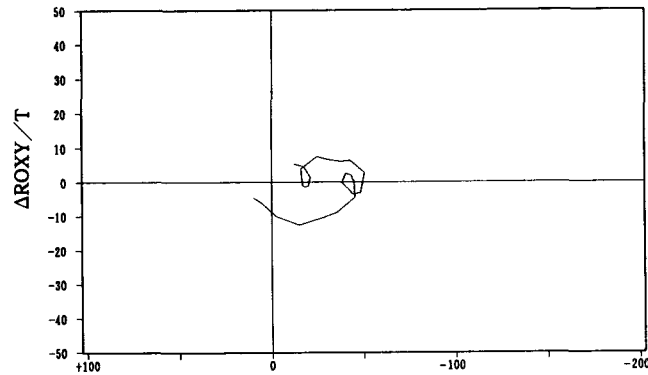

(c) ROXY index by five-year moving-average of population (1963-92)

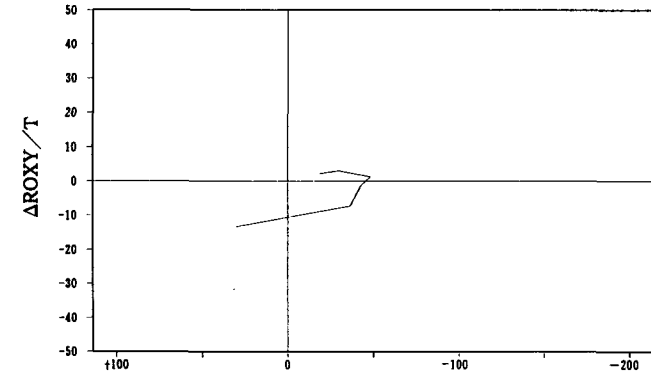

(d) ROXY index by National Population Census data (1960-90)

Figure N-5 Four Types of ROXY Indices and Their Marginal Values by Use of Moving-average of Population for Takasaki-line Region: Aggregated Case

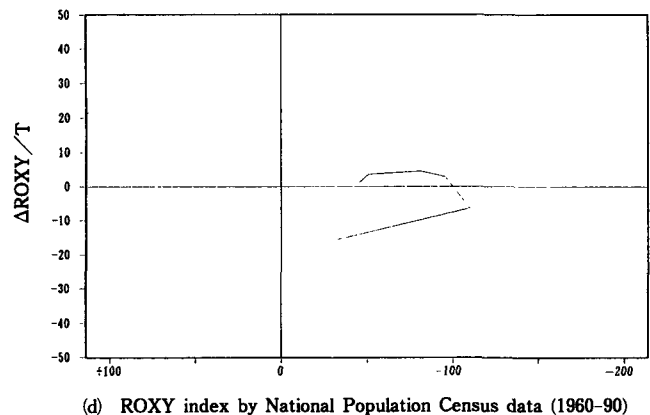
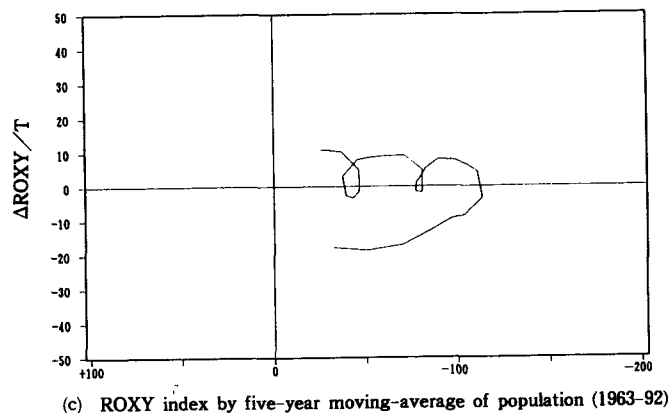
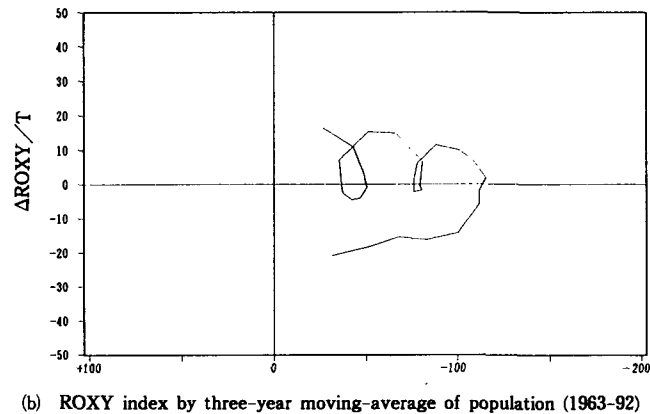
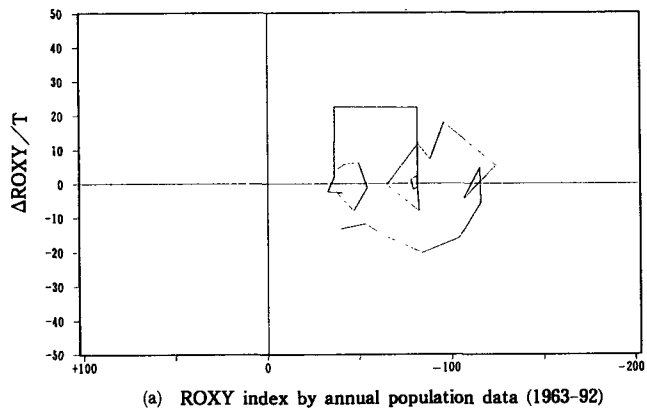
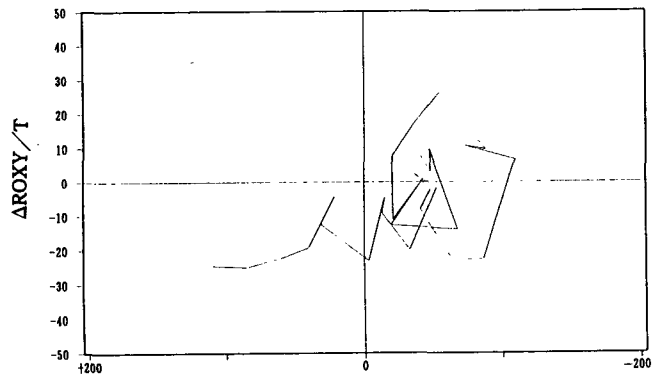
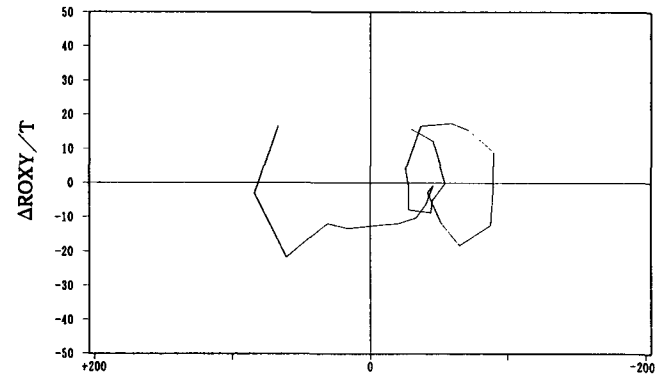

Figure N-6 Four Types of ROXY Indices and Their Marginal Values by Use of Moving-average of Population for Takasaki-line Region: Disaggregated Case



(a) ROXY index by annual population data (1963-92)



(b) ROXY index by three-year moving-average of population (1963-92)

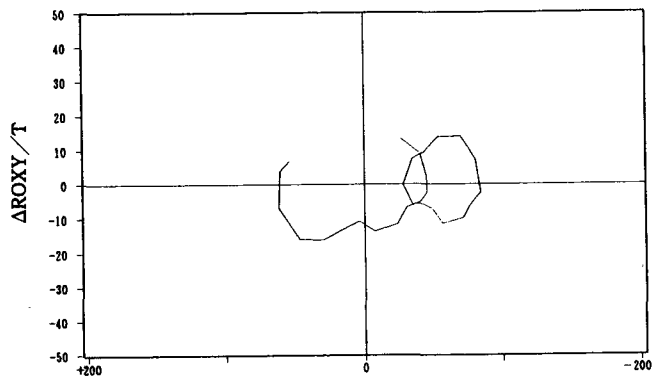

(c) ROXY index by five-year moving-average of population (1963-92)

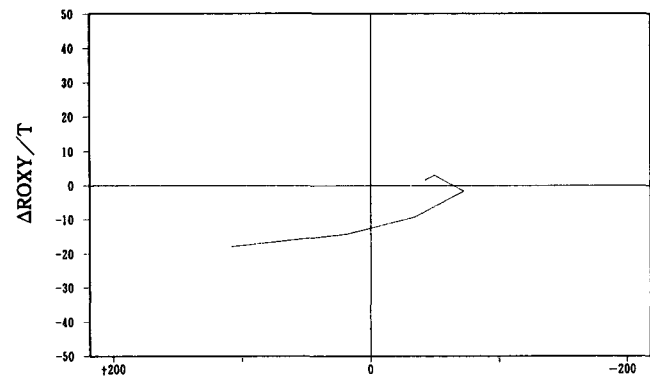

(d) ROXY index by National Population Census data (1960-90)

Figure N-7 Four Types of ROXY Indices and Their Marginal Values by Use of Moving-average of Population for Joban-line Region: Aggregated Case

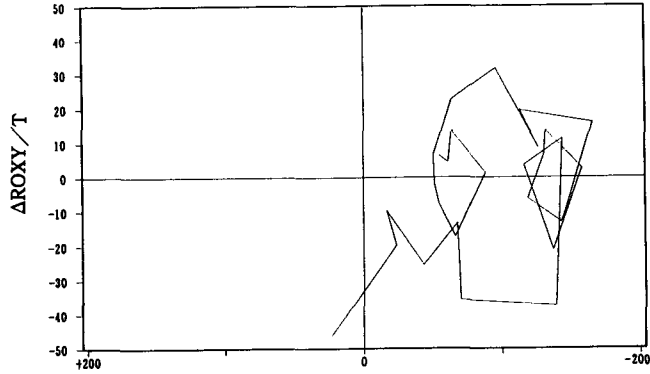

(a) ROXY index by annual population data (1963-92)

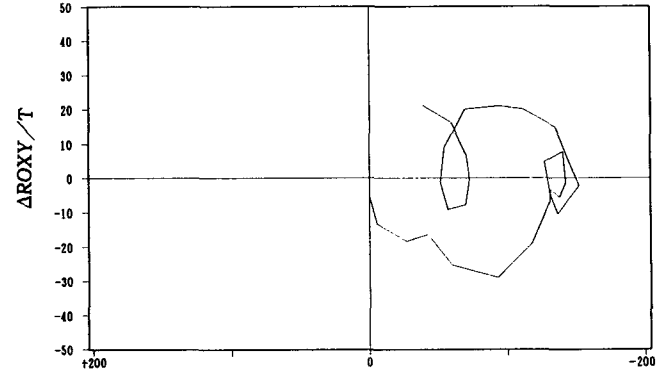

(b) ROXY index by three-year moving-average of population (1963-92)

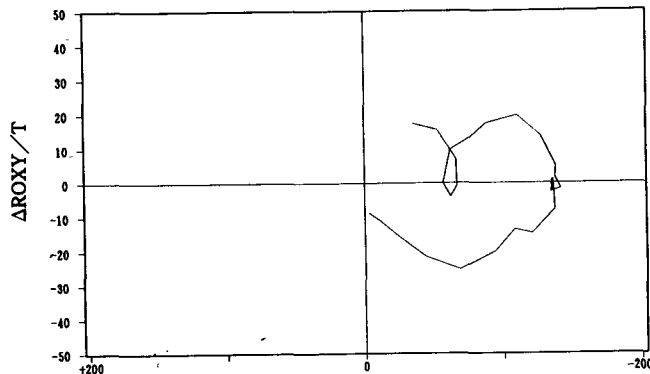

(c) ROXY index by five-year moving-average of population (1963-92)

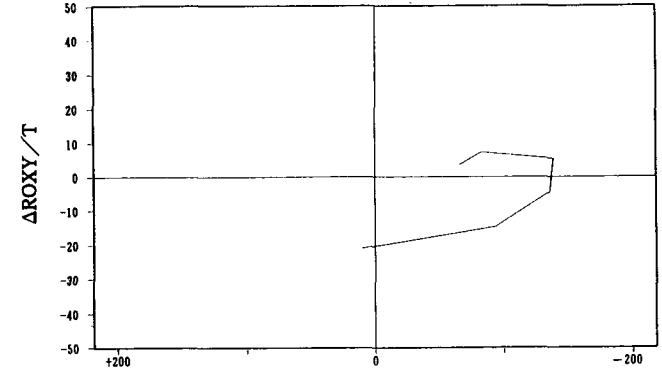

(d) ROXY index by National Population Census data (1960-90)

Figure N-8 Four Types of ROXY Indices and Their Marginal Values by Use of Moving-average of Population for Joban-line Region: Disaggregated Case

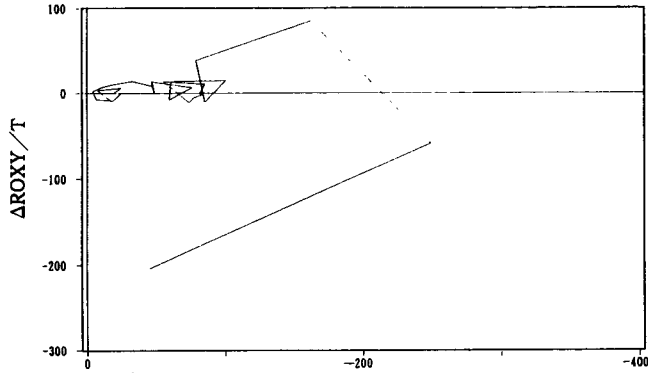

(a) ROXY index by annual population data (1963-92)

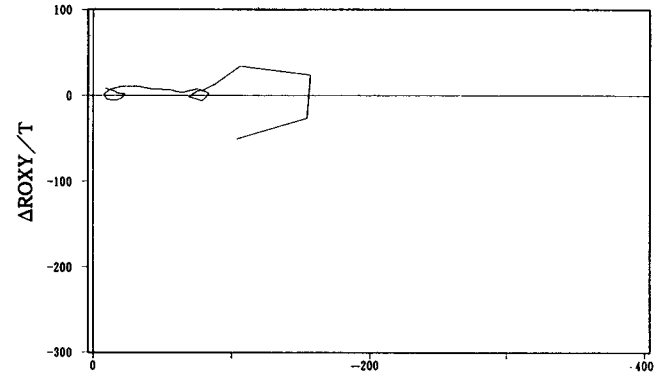

(b) ROXY index by three-year moving-average of population (1963-92)

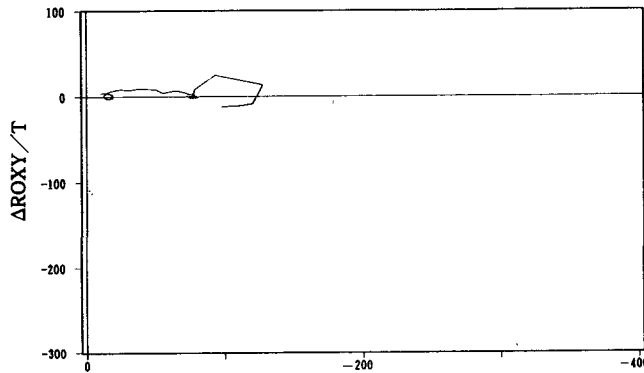

(c) ROXY index by five-year moving-average of population (1963-92)

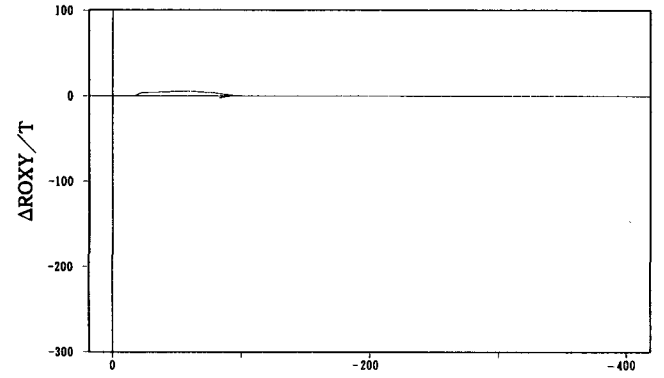

(d) ROXY index by National Population Census data (1960-90)

Figure N-9 Four Types of ROXY Indices and Their Marginal Values by Use of Moving-average of Population for Tokaido-line Region: Aggregated Case

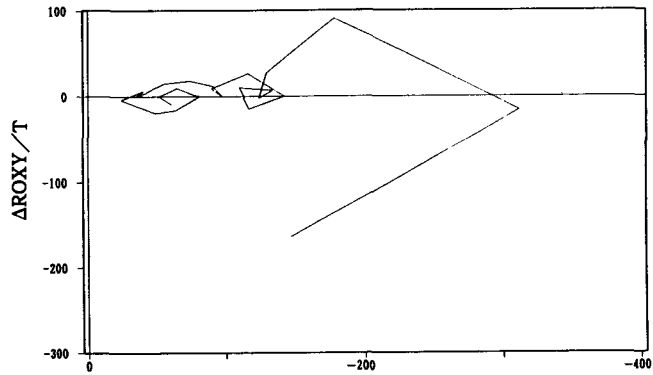

(a) ROXY index by annual population data (1963-92)

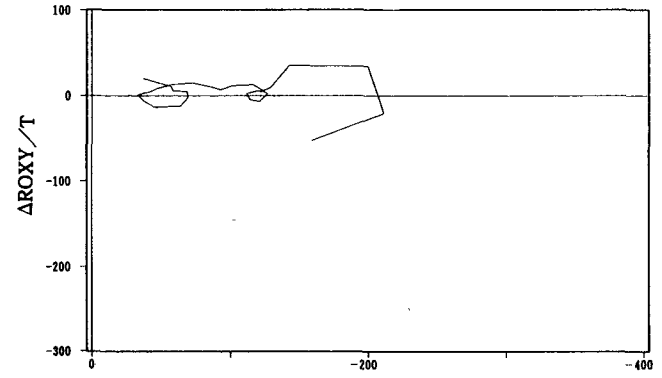

(b) ROXY index by three-year moving-average of population (1963-92)

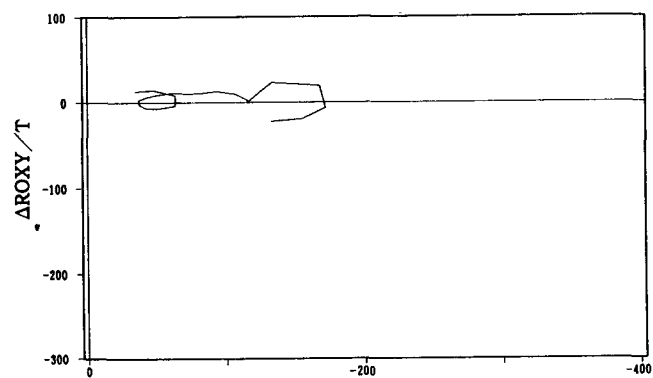

(c) ROXY index by five-year moving-average of population (1963-92)

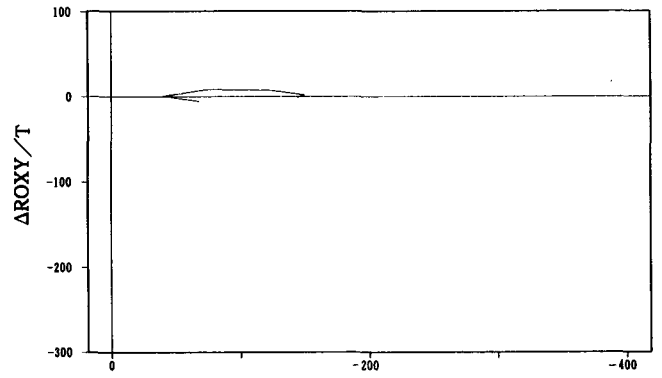

(d) ROXY index by National Population Census data (1960-90)

Figure N-10 Four Types of ROXY Indices and Their Marginal Values by Use of Moving-average of Population for Tokaido-line Region: Disaggregated Case

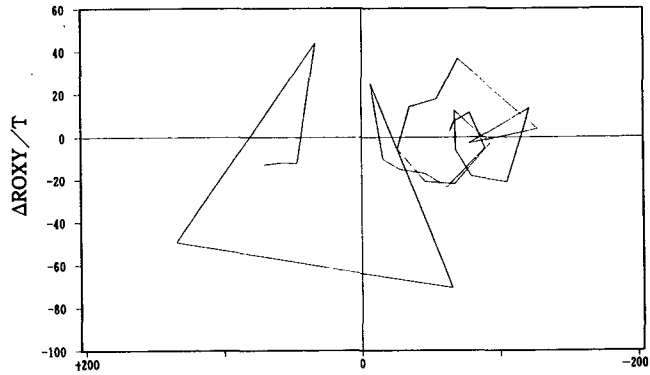

(a) ROXY index by annual population data (1963-92)

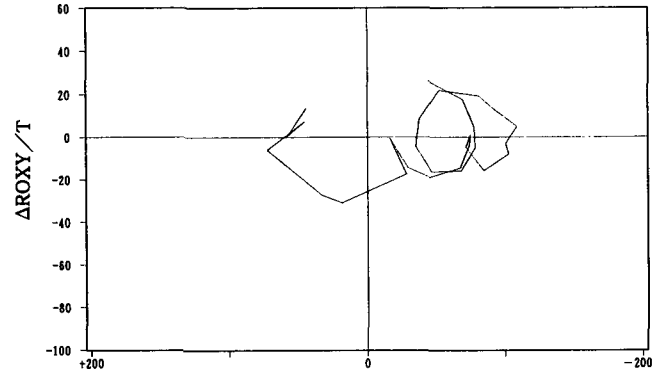

(b) ROXY index by three-year moving-average of population (1963-92)

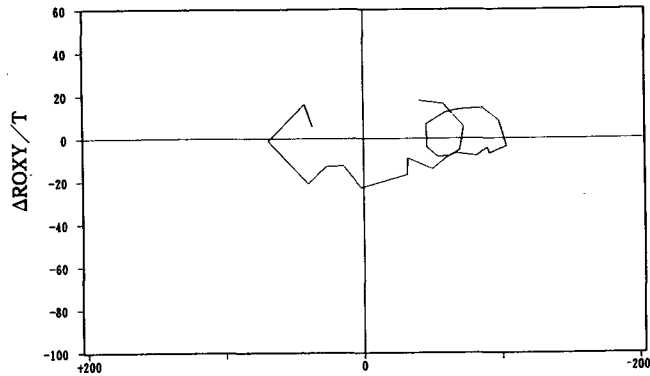

(c) ROXY index by five-year moving-average of population (1963-92)

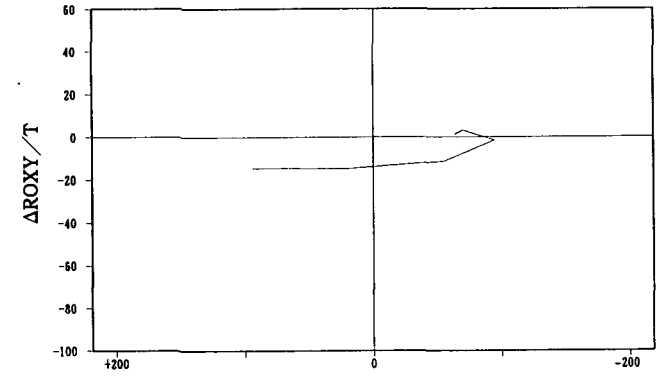

(d) ROXY index by National Population Census data (1960-90)

Figure N-11 Four Types of ROXY Indices and Their Marginal Values by Use of Moving-average of Population for Sobu-line Region: Aggregated Case

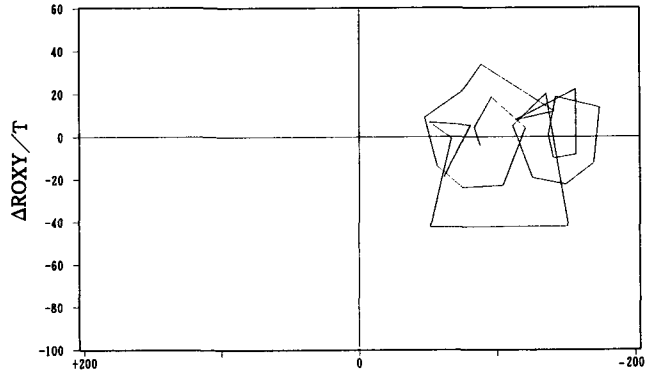

(a) ROXY index by annual population data (1963-92)

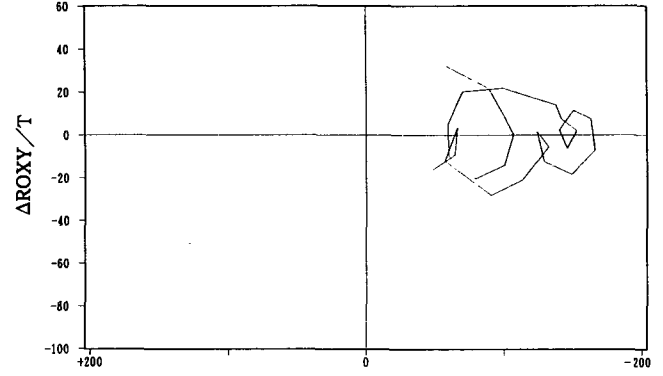

(b) ROXY index by three-year moving-average of population (1963-92)

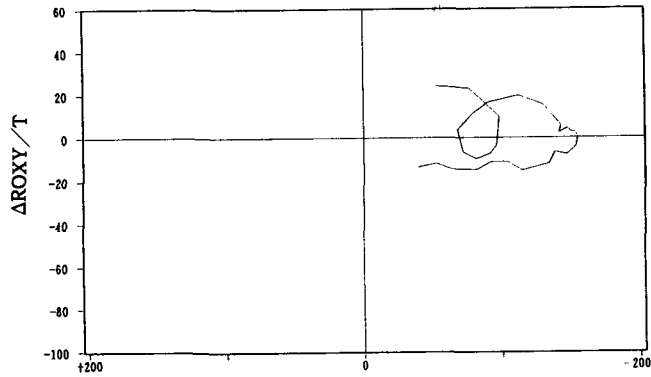

(c) ROXY index by five-year moving-average of population (1963-92)

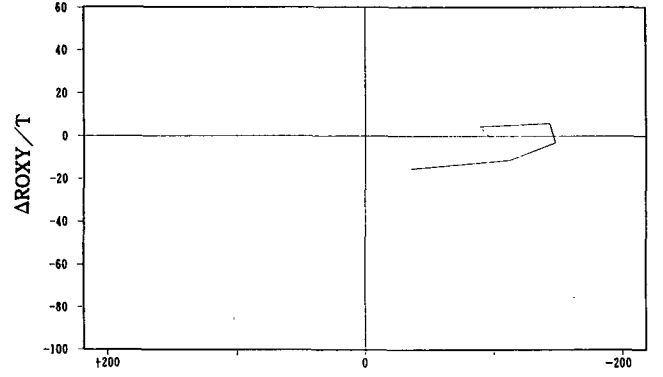

(d) ROXY index by National Population Census data (1960-90)

Figure N-12 Four Types of ROXY Indices and Their Marginal Values by Use of Moving-average of Population for Sobu-line Region: Disaggregated Case

$$\begin{aligned}
&= \frac{(d_{min} + d_{max}) \cdot \sum_{i=1}^n r_i^{t,t+1}}{\sum_{i=1}^n l_i} \cdot \frac{n}{\sum_{i=1}^n r_i^{t,t+1}} - \frac{\sum_{i=1}^n d_i}{n \cdot \bar{l}} \cdot \frac{\sum_{i=1}^n d_i \cdot r_i^{t,t+1}}{\sum_{i=1}^n d_i} \cdot \frac{n}{\sum_{i=1}^n r_i^{t,t+1}} - 1.0 \\
&= \frac{(d_{min} + d_{max})}{\bar{l}} - \frac{\bar{d}}{\bar{l}} \cdot \frac{\sum_{i=1}^n d_i \cdot r_i^{t,t+1}}{\sum_{i=1}^n d_i} \cdot \frac{n}{\sum_{i=1}^n r_i^{n,n+1}} - 1.0 \\
&= - \frac{\bar{d}}{\bar{l}} \left(\frac{\sum_{i=1}^n d_i \cdot r_i^{t,t+1}}{\sum_{i=1}^n d_i} \cdot \frac{n}{\sum_{i=1}^n r_i^{t,t+1}} - 1.0 \right) \\
&= - \frac{\bar{d}}{\bar{l}} \cdot R_d \times 10^{-4}
\end{aligned}$$

Notations employed in the above are the same in the text. This result shows (i) that the signs of R_d and R_l are different from each other, (ii) that the ratio of R_l to R_d is proportional to the ratio of the average CBD distance \bar{d} and average reversed distance \bar{l} , and (iii) that the absolute value of R_d equals to that of R_l when the average CBD distance equals to the average reversed distance.

- 7) The framework of the spatial-cycle hypothesis was initially conceived by Klaassen and Paelinck (1979). In an urban area, the central town is called the "core", and the surrounding municipalities that belong to the agglomeration are usually given the collective title "ring."
- 8) Population of the small area dx around the position of the distance x in one-dimensional linear region, is expressed as $n_l(x)dx$. The dimension of $n_l(x)$ is [persons \times length⁻¹].
- 9) Population of the small area $(dx)(x \cdot d\theta)$ around the position of the distance x and the angle θ in two-dimensional fan-shaped region, is expressed as $n_f(x, \theta)(dx)(x \cdot d\theta)$. The dimension of $n_f(x, \theta)$ is [person \times length⁻²].
- 10) Dirac's delta function was initially proposed by P. A. M. Dirac in 1930. Dirac's delta function $\delta(x)$ depends on a parameter x satisfying the conditions;

$$\int_{-\infty}^{\infty} \delta(x) dx = 1$$

$$\delta(x) = 0 \text{ for } x \neq 0.$$

To get a picture of $\delta(x)$, take a function of the real variable x which vanishes everywhere except inside a small domain, and which is extremely large inside this domain the integral over which is unity. The exact shape of the function inside this

domain does not matter. The most important property of $\delta(x)$, is exemplified by the following equation;

$$\int_{-\infty}^{\infty} f(x) \delta(x) dx = f(0),$$

where $f(x)$ is any continuous function of x . We can easily see the validity of this equation from the above picture of $\delta(x)$. The lefthand side can depend only on the values of $f(x)$ for the point very close to the origin, so that we may replace $f(x)$ by its value at the origin, $f(0)$. By making a change of origin in the above equation, we can deduce the formula as follows;

$$\int_{-\infty}^{\infty} f(x) \delta(x - a) dx = f(a),$$

where a is any real number. Thus the process of multiplying a function of x by $\delta(x - a)$ and integrating it over all x , is equivalent to the process of substituting a for x . For more details, see Dirac (1958).

- 11) Spline function is a kind of piecewise polynomial function, which is often employed for the task of curve-fitting. The third order spline function $s(x)$ employed in this paper is as follows;

$$s(x) = a_0 + a_1 x + \sum_{i=1}^n c_i (x - x_i)_+^3 \quad (\text{N-1})$$

where

a_0, a_1 and c_i : Appropriate coefficients

x_i : Positions of knots or joints of piecewise polynomial function which correspond to the positions of subareas. In this paper, x_1 and x_n is equals to d_0 and d_1 respectively.

$(x - x_i)_+^3$: Truncated power function which is defined as $(x - x_i)^3$ when $(x - x_i)$ is positive, and as zero when $(x - x_i)$ is zero or negative. The shape of this function appears as shown in Figure N-13.

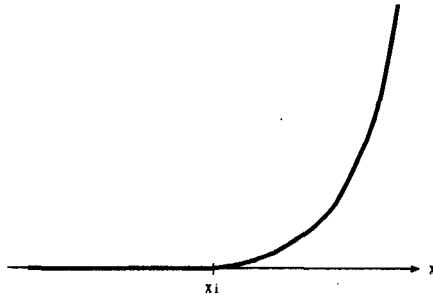

Figure N-13 Graph of $(x - x_i)_+^3$

It is clear that $s(x)$ is twice continuously differentiable all over x , but is not three times differentiable. In fact, our truncated power function is not three times differentiable as can be seen below;

$$\frac{d^3}{dx^3} (x - x_i)_+^3 = \begin{cases} 6 & \text{when } x > x_i \\ 0 & \text{when } x < x_i \\ \text{undefined at} & x = x_i \end{cases} \quad (\text{N-2})$$

The condition that the spline function must satisfy in order to interpolate the data (x_j, y_j) ($j = 1, 2, \dots, n$), is as follows;

$$s(x_j) = y_j \quad (j = 1, 2, \dots, n) \quad (\text{N-3})$$

$$\sum_{i=1}^n C_i x_i^r = 0 \quad (r = 0, 1, \dots, k-1) \quad (\text{N-4})$$

To give an example of interpolation of the spline function, let us assume that the data series (x_i, y_i) are $(-3, 7)$, $(-1, 11)$, $(0, 26)$, $(3, 56)$, $(4, 29)$. The formulation of the interpolation function for this case, is as follows;

$$s(x) = a_0 + a_1 x + c_1(x+3)_+^3 + c_2(x+1)_+^3 + c_3 x^3 + c_4(x-3)_+^3 + c_5(x-4)_+^3 \quad (\text{N-5})$$

The condition that the function can interpolate the data (x_i, y_i) , is as follows;

$$\begin{cases} a_0 - 3a_1 & = 7 \\ a_0 - a_1 + 8c_1 & = 11 \\ a_0 + 27c_1 + c_2 & = 26 \\ a_0 + 3a_1 + 216c_1 + 64c_2 + 27c_3 & = 56 \\ a_0 + 4a_1 + 243c_1 + 125c_2 + 64c_3 + c_4 & = 29 \\ c_1 + c_2 + c_3 + c_4 + c_5 & = 0 \\ -3c_1 - c_2 + 3c_4 + 4c_5 & = 0 \end{cases} \quad (\text{N-6})$$

Solving this linear simultaneous equations, we can get the following interpolation function;

$$s(x) = 1 - 2x + (x+3)^2 - 2(x+1)^2 - x^2 + 7(x-3)^2 - 5(x-4)^2 \quad (N-7)$$

More detailed explanation on the spline function is furnished in Prenter (1975).

- 12) The spatial redistribution processes of population in the regions consisting of localities situated along each of major railway lines among which is included the Takasaki-line, have been analyzed by the conventional ROXY index in Kawashima (1986a, 1986b, 1986c and 1987).

References

- Dirac, P.A.M., 1958, *The Principles of Quantum Mechanics, Fifth Edition*, Oxford University Press, London, England.
- Kawashima, T., 1978, "Recent Urban Evolution Processes in Japan: Analysis of Functional Urban Regions," Presented at the 25th North American Meetings of the Regional Science Association, Chicago, Illinois, U.S.A., November.
- Kawashima, T., 1982, "Recent Trends in Japan: Analysis of Functional Urban Regions" in T. Kawashima and P. Korcelli (eds.), *Human Settlement System: Spatial Patterns and Trends*, International Institute for Applied Systems Analysis, Laxenburg, Austria, pp.21-40.
- Kawashima, T., 1986a, "Speed of Suburbanization: ROXY Index Analysis for Intra-metropolitan Spatial Redistribution of Population in Japan," *Gakushuin Economic Papers*, Vol.22, No.3, Gakushuin University, Tokyo, March, pp.243-304.
- Kawashima, T., 1986b, "People Follow Jobs in Japan?: Suburbanization of Job Markets," *Gakushuin Economic Papers*, Vol.23, No.1 & 2, Gakushuin University, Tokyo, October, pp.157-183.
- Kawashima, T., 1986c, "Spatial Cycle Race 1985: ROXY Index Analysis of the 1985 Population Census for Three Railway-line Regions in the Tokyo Metropolitan Area," *Gakushuin Economic Papers*, Vol.23, No.3, Gakushuin University, Tokyo, December, pp.53-70.
- Kawashima, T., 1987, "ROXY Index Analysis of Population Changes in Japan for 1960-1985: Spatial (De)centralization and (De)concentration," *Gakushuin Economic Papers*, Vol.24, No.3, Gakushuin University, Tokyo, December, pp.11-39.
- Kawashima, T., and N. Hiraoka, 1993a, "Centralization and Suburbanization: ROXY Index Analysis for Five Railway-line Regions in Tokyo Metropolitan Area," *Gakushuin Economic Papers*, Vol.30, No.1, Gakushuin University, Tokyo, March, pp.203-230.
- Kawashima, T., and N. Hiraoka, 1993b, "Mathematical Characteristics of ROXY Index (I): Distance and Reversed Distance Used as Weighing Factors," *Gakushuin Economic*

- Papers*, Vol.30, No.2, Gakushuin University, Tokyo, July, pp.255-297.
- Kawashima, T., N. Hiraoka, A. Okabe and N. Ohtera, 1993, "Metropolitan Analyses: Boundary Delineations and Future Population Changes of Functional Urban Region," *Gakushuin Economic Papers*, vol.29, No.3, Gakushuin University, Tokyo, January, pp.205-248.
- Klaassen, L.H. and J.H.P. Paelinck, 1979, "The Future of Large Towns," *Environment and Planning A*, Vol.11, No.11, pp.1095-1104.
- Klaassen, L.H., J.A. Bourdrez and J. Volmuller, 1981, *Transport and Reurbanisation*, Gower, Hants, England.
- Prenter, P., 1975, *Splines and Variational Methods*, John Wiley and Sons, New York, U.S.A.

Appendix

Table A-1 Code Numbers, Names and Distance for Localities in Takasaki-line Region

Code Number	Name	Distance(km)	Type-a	Type-s
13100	Tokubetsu-kubu	7.4	○	
13106	Daito-ku	4.2		○
13118	Arakawa-ku	6.7		○
13117	Kita-ku	8.9		○
11203	Kawagushi-shi	14.8	○	○
11223	Warabi-shi	18.0	○	○
11204	Urawa-shi	23.2	○	○
11220	Yono-shi	26.0	○	○
11205	Ohmiya-shi	28.0	○	○
11219	Ageo-shi	36.5	○	○
11231	Okegawa-shi	40.2	○	○
11233	Kitamoto-shi	44.0	○	○
11217	Kohnosu-shi	48.0	○	○
11304	Fukiage-machi	54.5	○	○
11206	Gyohda-shi	58.0	○	○

[Note] The circle marks show which subareas belong to Type-a or Type-b, or both of them.

Table A-2 Population for Localities in Takasaki-line Region

Code	1960	1965	1970	1975	1980	1985	1990
13100	8,310,027	8,893,094	8,840,942	8,642,800	8,349,209	8,354,615	8,163,573
13106	318,889	286,324	240,769	207,649	186,048	176,804	162,969
13118	285,480	278,412	247,013	217,905	198,126	190,061	184,809
13117	418,603	452,064	431,219	419,996	387,458	367,579	354,647
11203	173,692	249,112	305,886	345,547	379,357	403,015	438,680
11223	50,952	69,715	77,225	76,312	70,876	70,408	73,620
11204	174,437	221,323	269,397	331,145	358,180	377,235	418,271
11220	40,840	51,746	62,802	71,045	72,326	70,597	79,060
11205	169,996	215,646	268,777	327,696	354,082	373,022	403,776
11219	38,889	54,776	110,792	146,359	166,244	178,587	194,947
11231	21,309	28,108	38,717	48,034	55,746	61,499	69,029
11233	15,483	20,576	31,699	46,632	50,888	58,114	63,929
11217	31,868	36,526	41,990	51,632	57,085	60,565	72,435
11304	12,095	14,482	17,247	18,775	22,606	24,990	26,928
11206	54,746	56,152	60,135	66,069	73,205	79,359	83,181

(Unit: persons)

Table A-3 Five-year Growth Rate of Population for Localities in Takasaki-line Region

Code	1960-1965	1965-1970	1970-1975	1975-1980	1980-1985	1985-1990
13100	7.02	-0.59	-2.24	-3.40	0.06	-2.29
13106	-10.21	-15.91	-13.76	-10.40	-4.96	-7.83
13118	-2.48	-11.28	-11.78	-9.08	-4.07	-2.76
13117	7.99	-4.61	-2.60	-7.75	-5.13	-3.52
11203	43.42	22.79	12.97	9.78	6.24	8.85
11223	36.82	10.77	-1.18	-7.12	-0.66	4.56
11204	26.88	21.72	22.92	8.16	5.32	10.88
11220	26.70	21.37	13.13	1.80	-2.39	11.99
11205	26.85	24.64	21.92	8.05	5.35	8.24
11219	40.85	102.26	32.10	13.59	7.42	9.16
11231	31.91	37.74	24.06	16.06	10.32	12.24
11233	32.89	54.06	47.11	9.13	14.20	10.01
11217	14.62	14.96	22.96	10.56	6.10	19.60
11304	19.74	19.09	8.86	20.40	10.55	7.76
11206	2.57	7.09	9.87	10.80	8.41	4.82

(Unit: percent)

Table A-4 Annual Growth Ratio of Population for Localities in Takasaki-line Region

Code	1960-1965	1965-1970	1970-1975	1975-1980	1980-1985	1985-1990
13100	1.0137	0.9988	0.9955	0.9931	1.0001	0.9954
13106	0.9787	0.9659	0.9708	0.9783	0.9899	0.9838
13118	0.9950	0.9764	0.9752	0.9811	0.9917	0.9944
13117	1.0155	0.9906	0.9947	0.9840	0.9895	0.9929
11203	1.0748	1.0419	1.0247	1.0188	1.0122	1.0171
11223	1.0647	1.0207	0.9976	0.9853	0.9987	1.0090
11204	1.0488	1.0401	1.0421	1.0158	1.0104	1.0209
11220	1.0485	1.0395	1.0250	1.0036	0.9952	1.0229
11205	1.0487	1.0450	1.0404	1.0156	1.0105	1.0160
11219	1.0709	1.1513	1.0573	1.0258	1.0144	1.0177
11231	1.0569	1.0661	1.0441	1.0302	1.0198	1.0234
11233	1.0585	1.0903	1.0803	1.0176	1.0269	1.0913
11217	1.0277	1.0283	1.0422	1.0203	1.0119	1.0364
11304	1.0367	1.0356	1.0171	1.0378	1.0203	1.0151
11206	1.0051	1.0138	1.0190	1.0207	1.0163	1.0095